

Разрѣзь трансепта по С D. (см. планъ.)

Фасадъ трансепта.

Чер. 1.

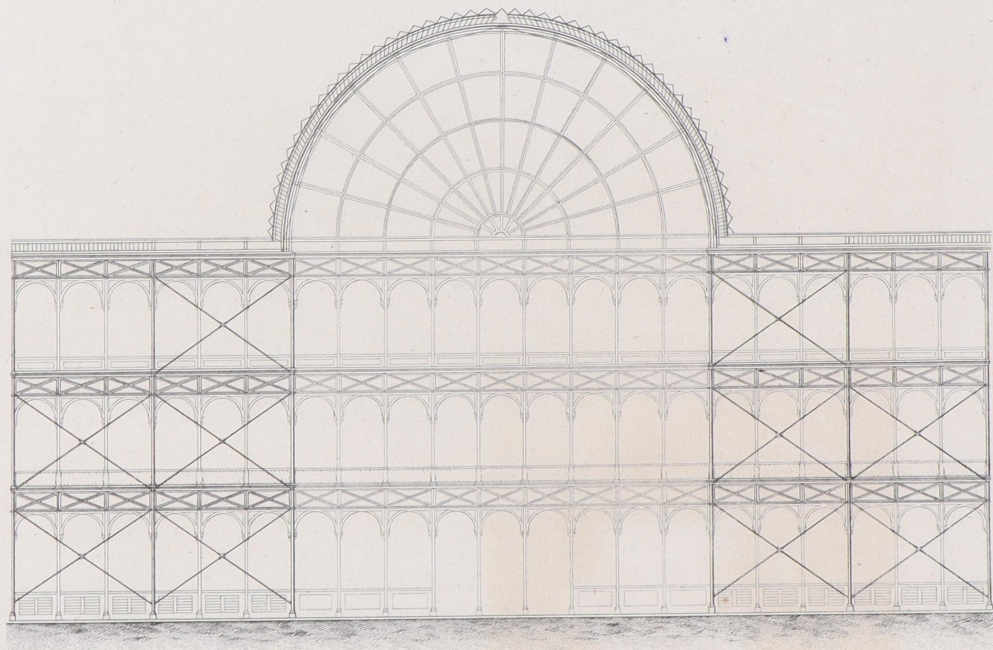

Чер. 2.

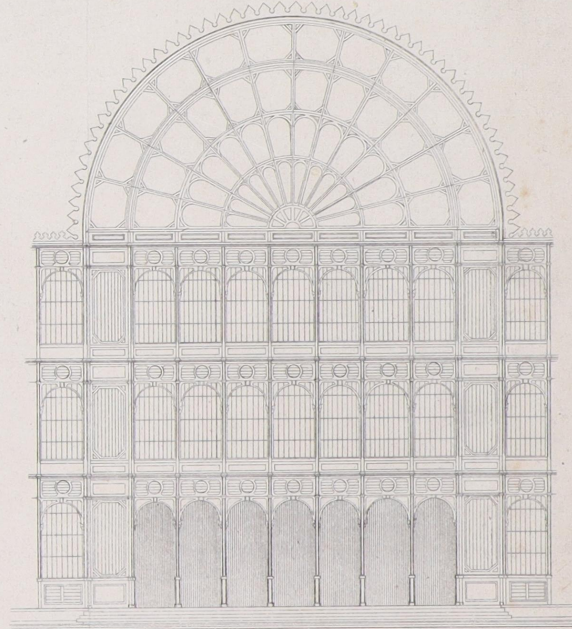

0 10 20 30 40 50 60 70 футов.

БИБЛИОТЕКА
Белорусскаго
института инженеров
железнодорожнаго
транспорта

1991

Поперечный разрывъ продолжнаго строения по А В. (см планъ)

Чер. 3.

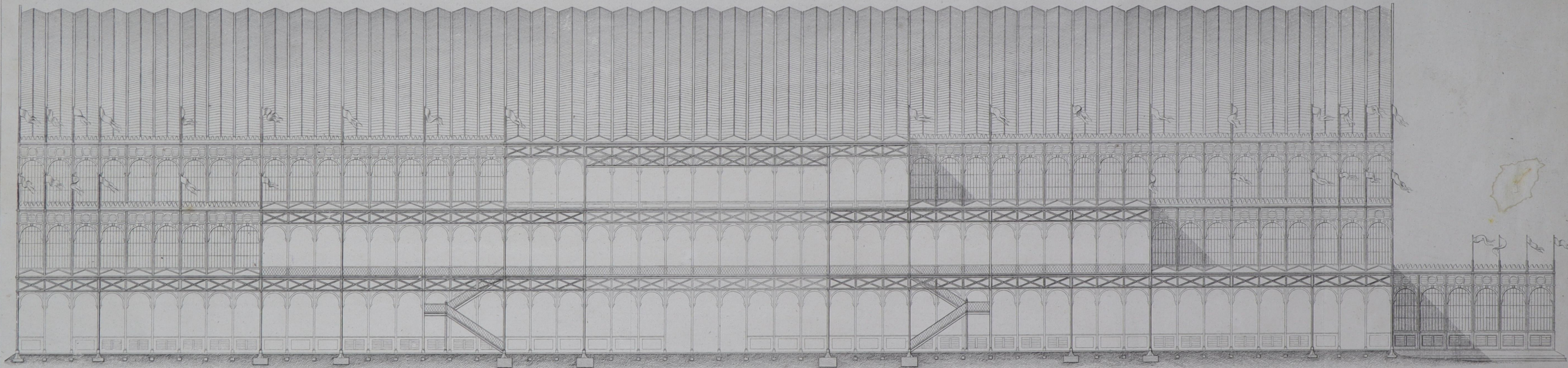

3882

1975

0 10 20 30 40 50 60 70 футъ.

Планъ галлерей.

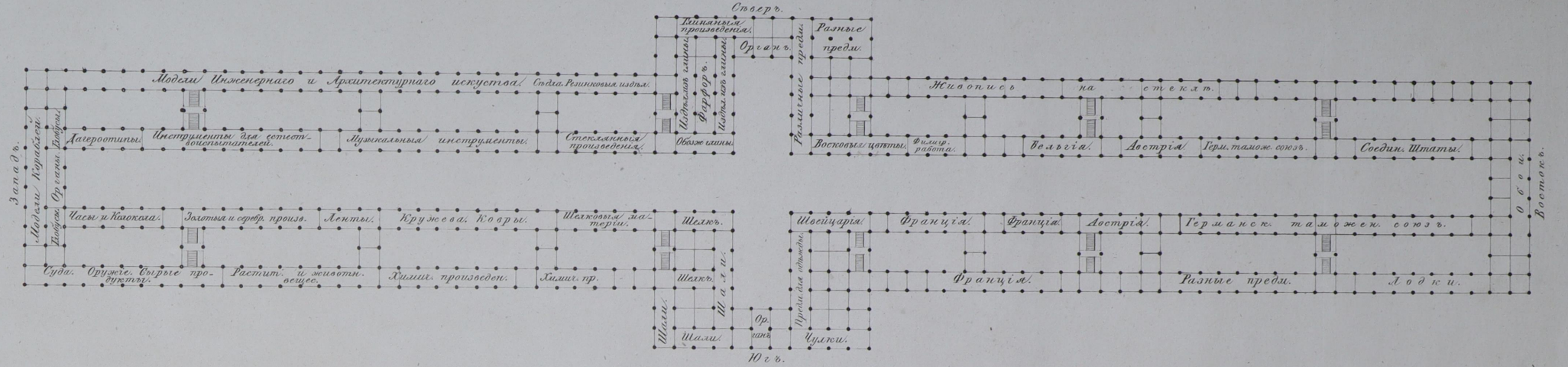

Планъ нижняго этажа зданія выставки

Чер. 4

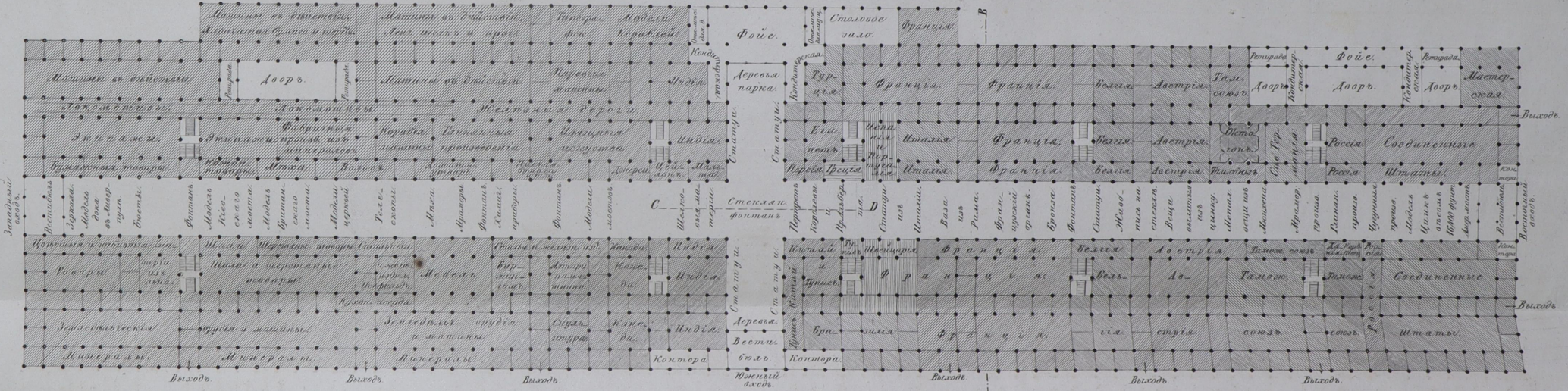

Виде прехъ-аманской стланы

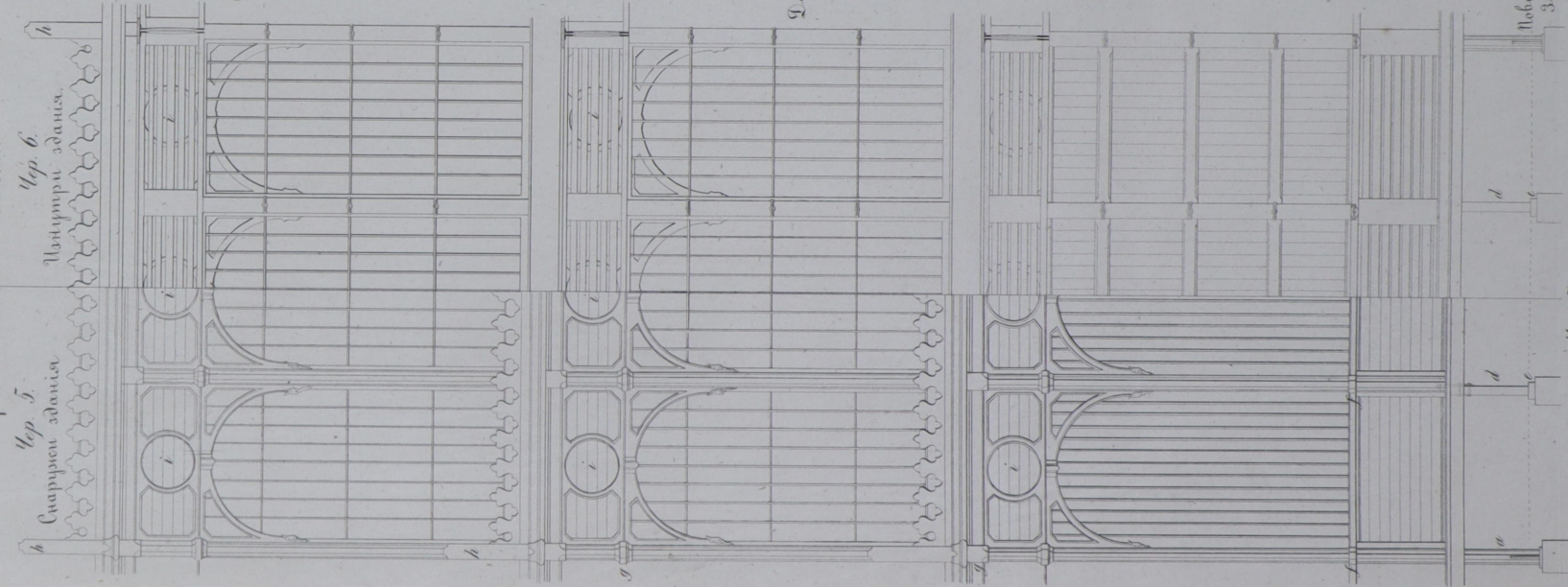

Виде прехъ-аманской стланы

Панорама здания

Панорама здания
24 фута

Чер. 13.

Видъ одно-этажной стѣны зданія - снаружси

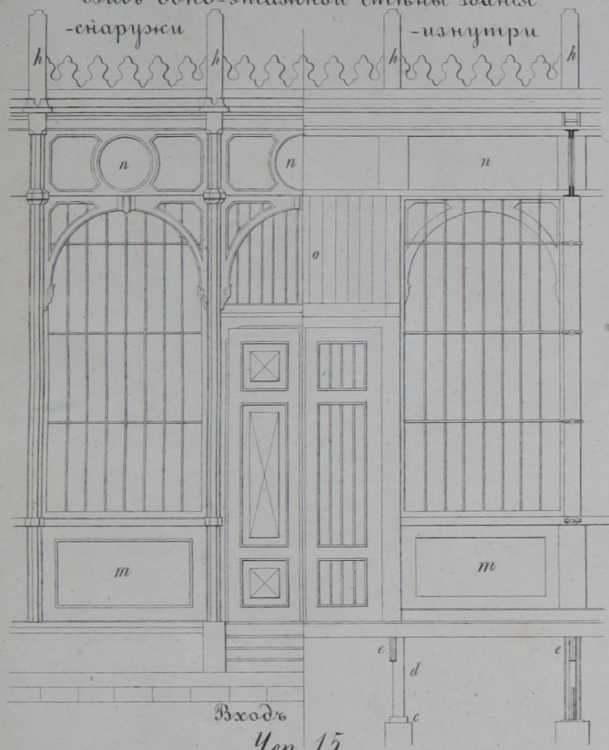

Чер. 14.

Видъ одно-этажной стѣны зданія - изнутри

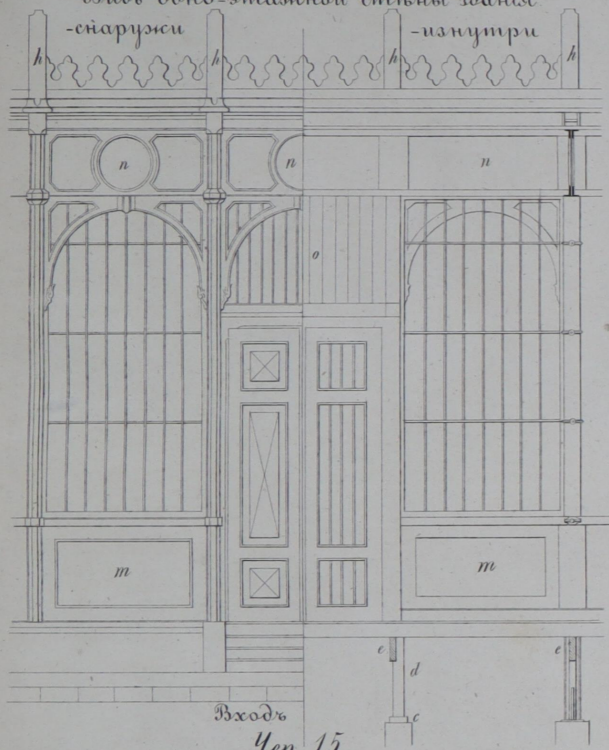

Чер. 16.

Деталь діагональныхъ связей

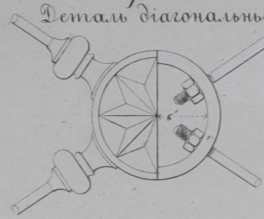

Чер. 17.

Видъ рѣшетки на галереяхъ

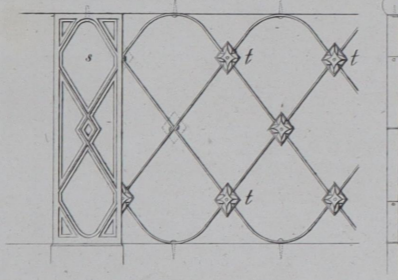

Чер. 18.

Къ Чер. 5-11, 13-15.

5 0 5 15 футовъ.

Къ статьѣ: испытаніе осей паровозовъ и вагоновъ.

Чер. 1.

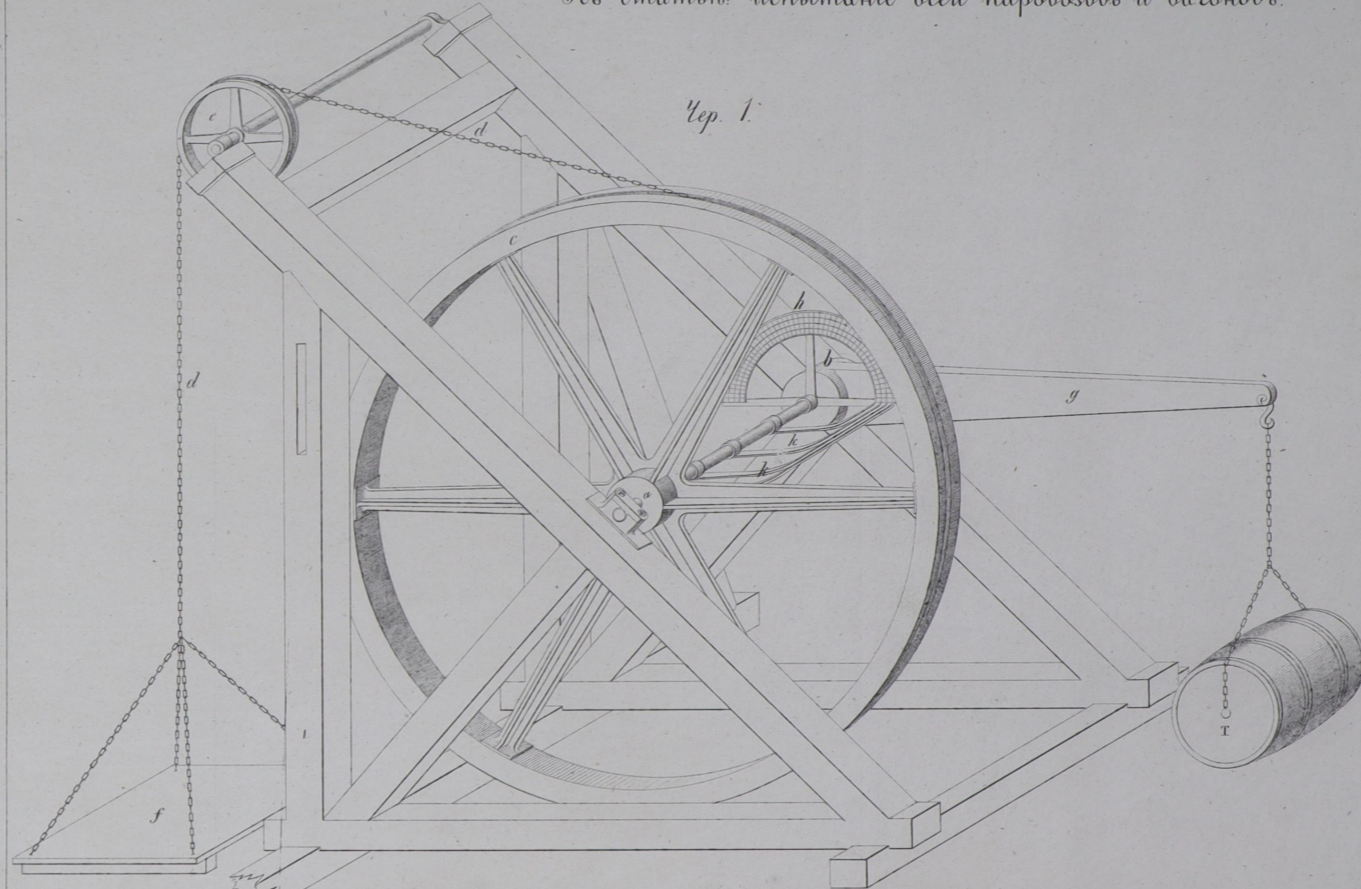

Чер. 2.

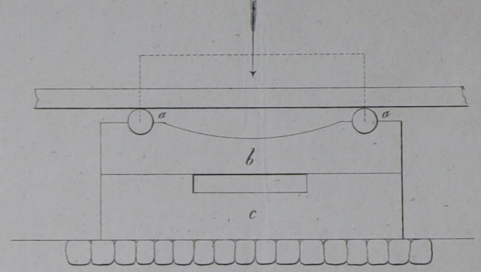

Чер. 3.

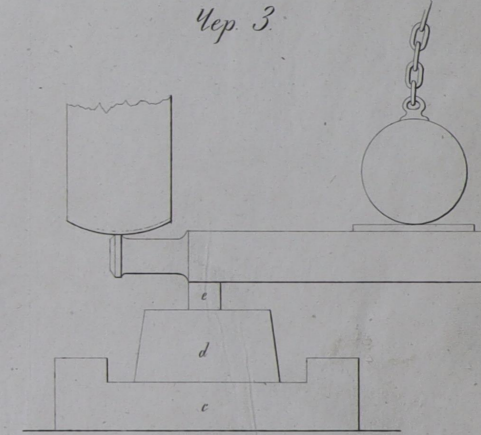

Чер. 26

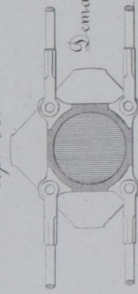

Чер. 21

Сопли гуртовой колонны

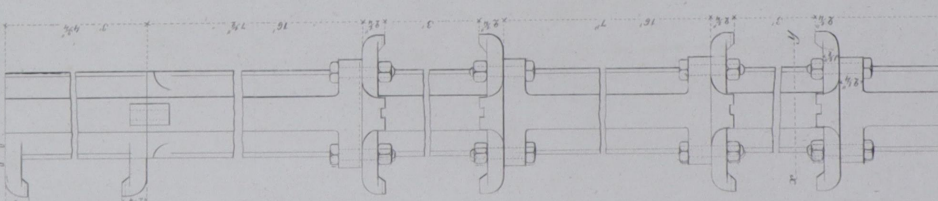

Планъ по x y

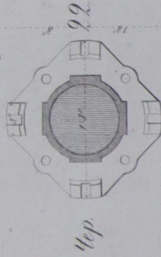

База колонны

Чер. 23

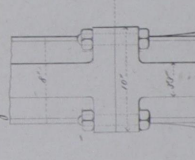

Планъ сѣчи колонны

Чер. 24

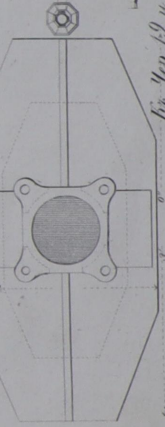

Чер. 19 и 20

Чер. 25

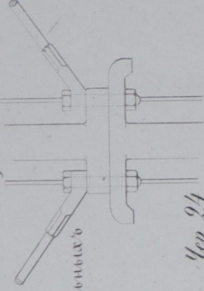

Сопли балочныхъ свѣзей

Чер. 24

Видъ передъ стѣной въ 24 фута ширины

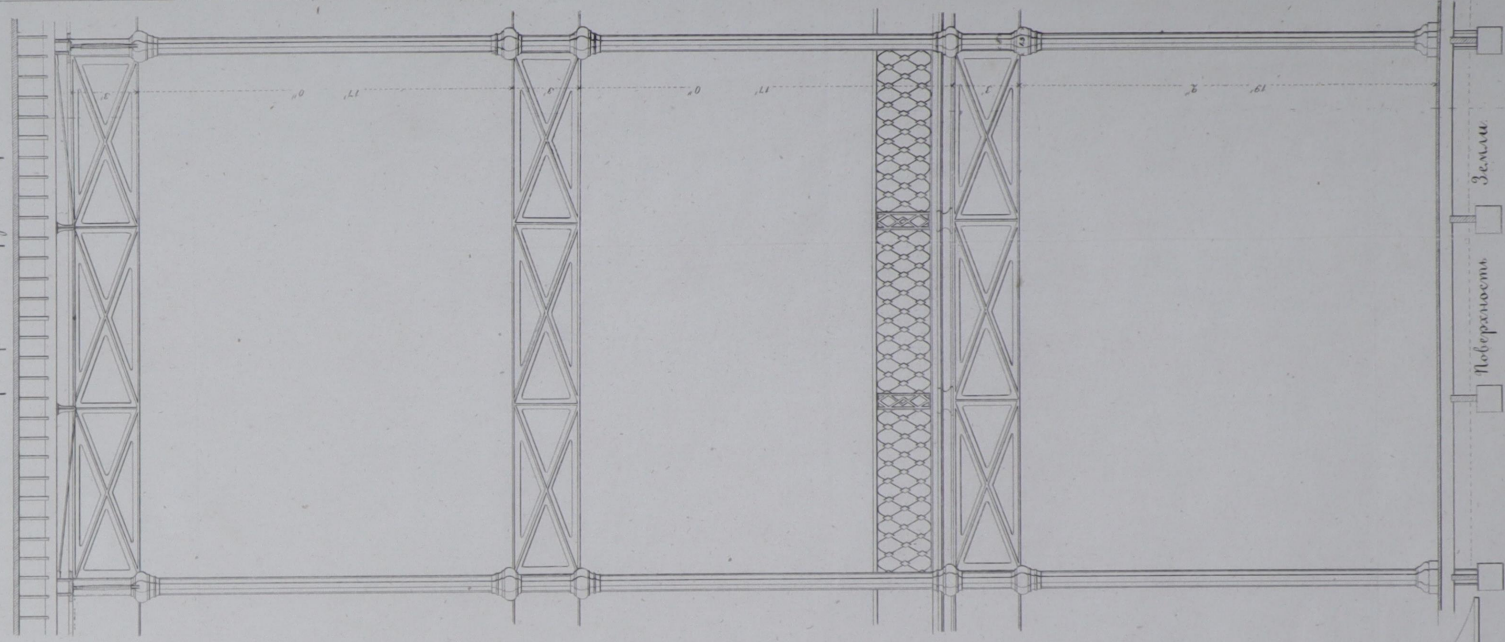

Земля

Чер. 20

Планъ

Чер. 12, 21 — 26

0 футовъ

10

20

30 футовъ

Чер. 27.

Видъ фермы средняго 72 футоваго пролета

Чер. 30.

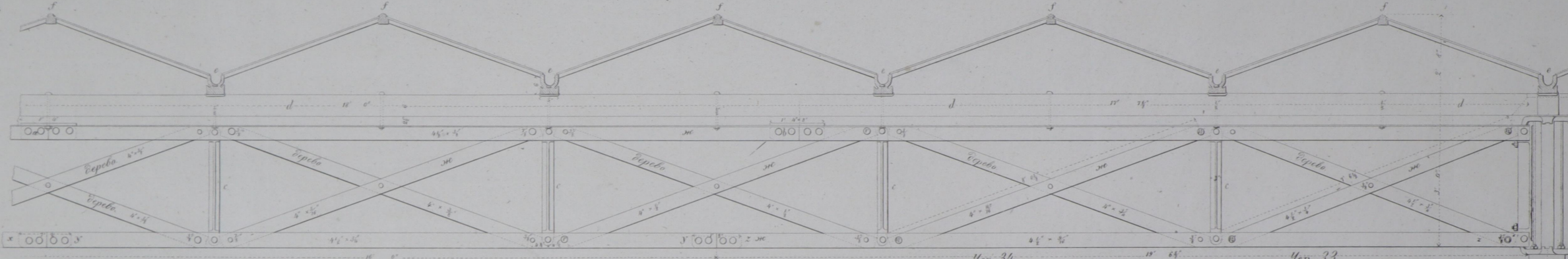
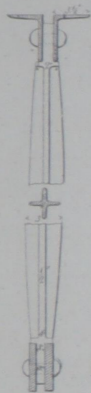

Чер. 31. Чер. 32.

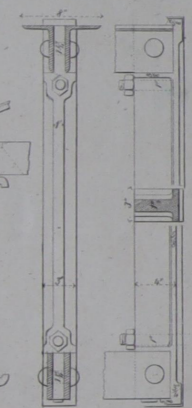

Чер. 28.

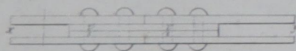

Чер. 29.

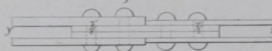

Чер. 34.

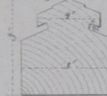

Разрѣзь конька.

Чер. 33.

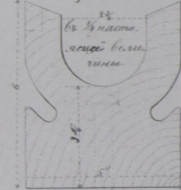

Разрѣзь жолоба

къ Чер. 27.

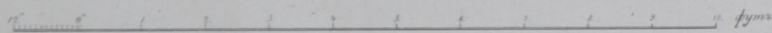

къ Чер. 28-34.

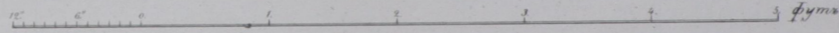

Видъ фермы на которую опираются арки трансепта.

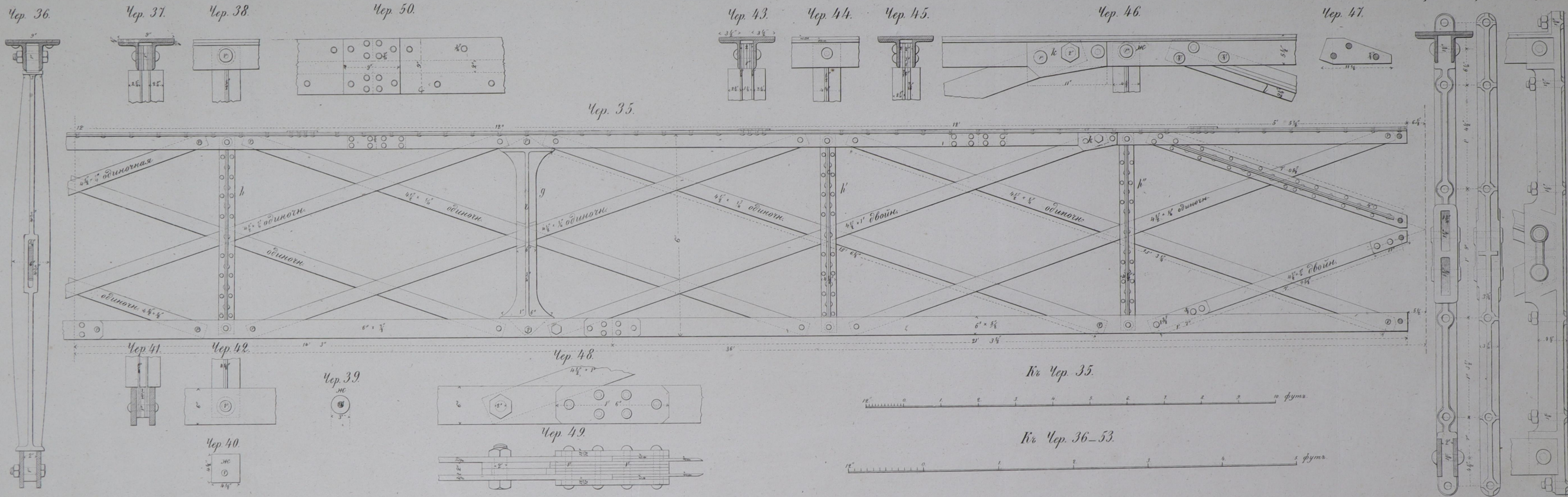

Запись части означенныя буквами м-малыя и-крупныя.

Чер. 64.

Детали арочной фермы надъ

ной фермы въ 72 фута трансептомъ.

Чер. 69. Передній фасадъ части арочной фермы.

Чер. 71. Конекъ

Чер. 70.

Разрѣзъ пролета купольной фермы.

Чер. 67.

Разрѣзъ главной фермы

Чер. 68.

Подушка обхватывающая главное ребро.

Къ Чер. 64-66.

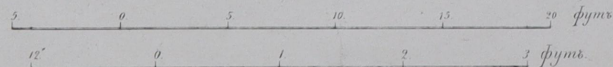

Чер. 65. Стекланная крыша трансепта. Изнутри

Чер. 66. Снаружи

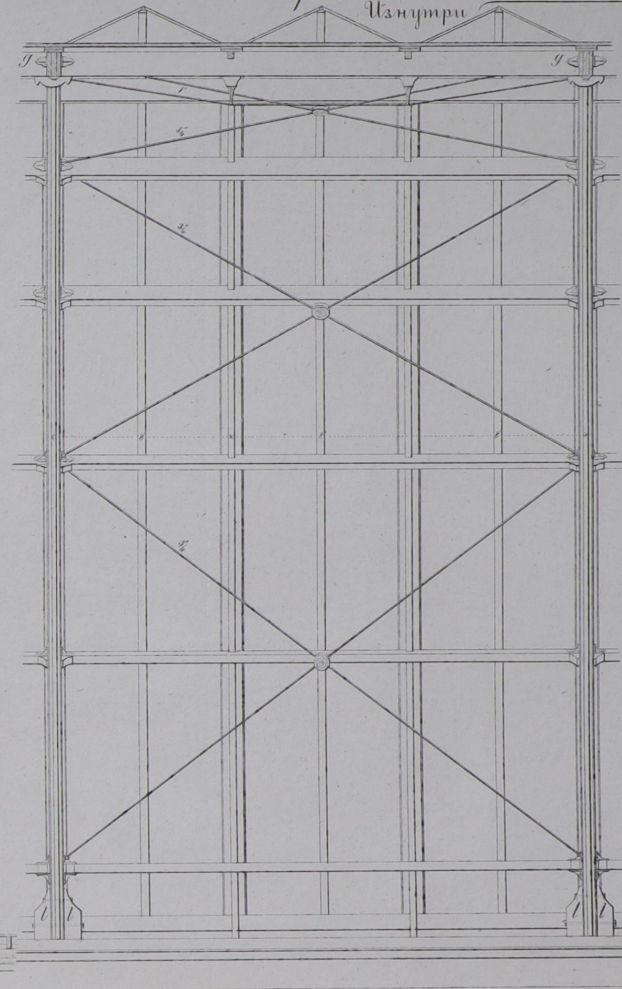

Детали пола галлерей.

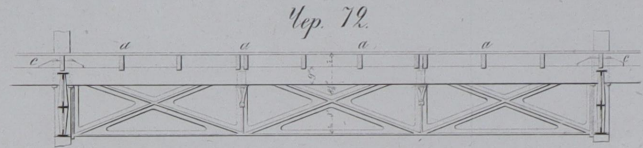

Чер. 12

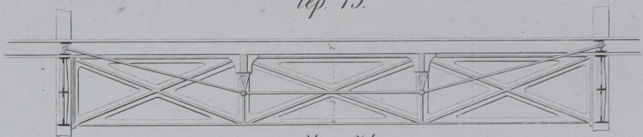

Чер. 13



Чер. 14

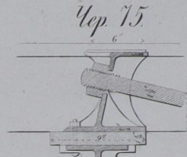

Чер. 15

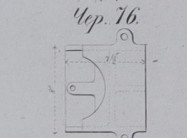

Чер. 16

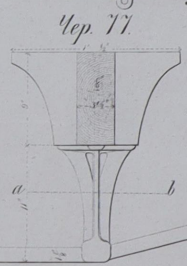

Чер. 17

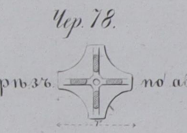

Чер. 18

Разрѣзъ по а-б.

Чер. 19
Пята арочнаго ребра
лежащая на колоннѣ.

Планъ

Вертик. разрѣзъ.

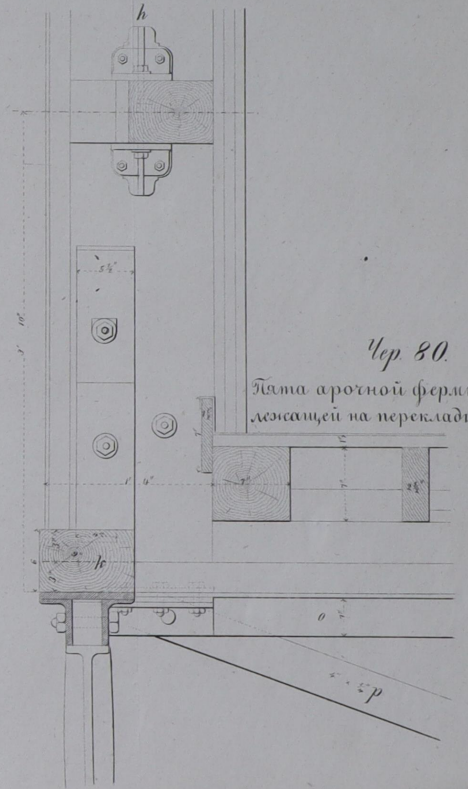
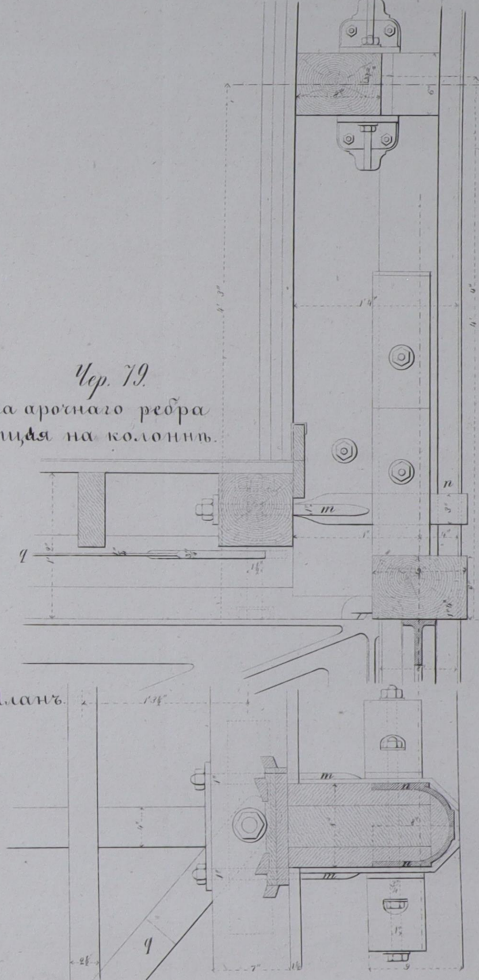

Чер. 20
Пята арочной фермы
лежащей на перекладинѣ.

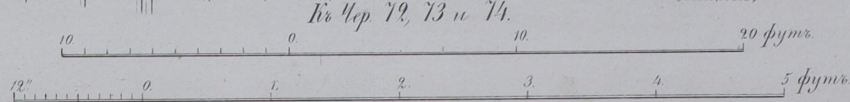

Начертаніе Г. У. путей сообщенія и проч. 1844 г. Т. IV

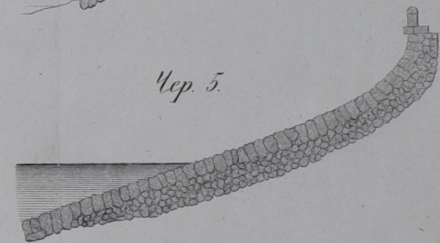
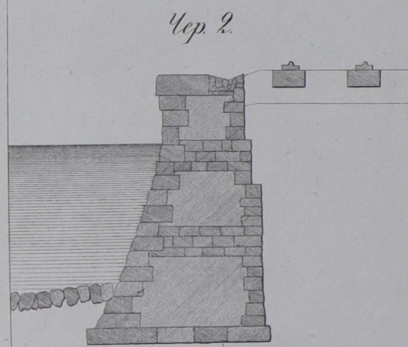
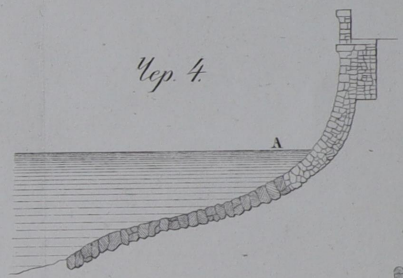
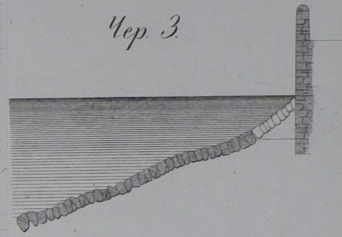
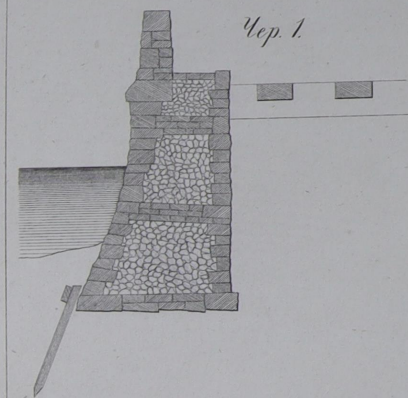
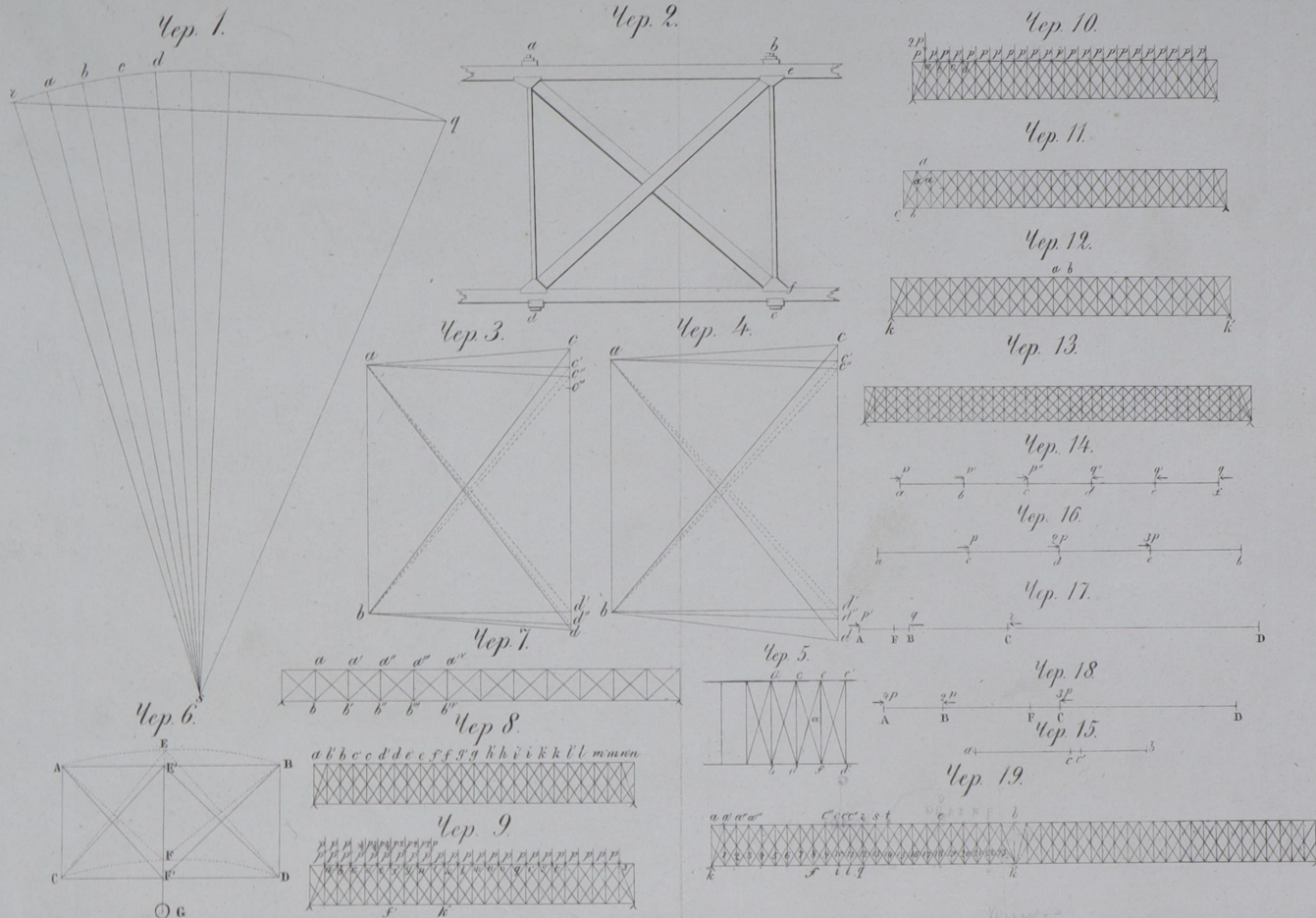

Віадукъ Ньюкастльської желѣзной дороги.

Чер. 1. Фасадъ.

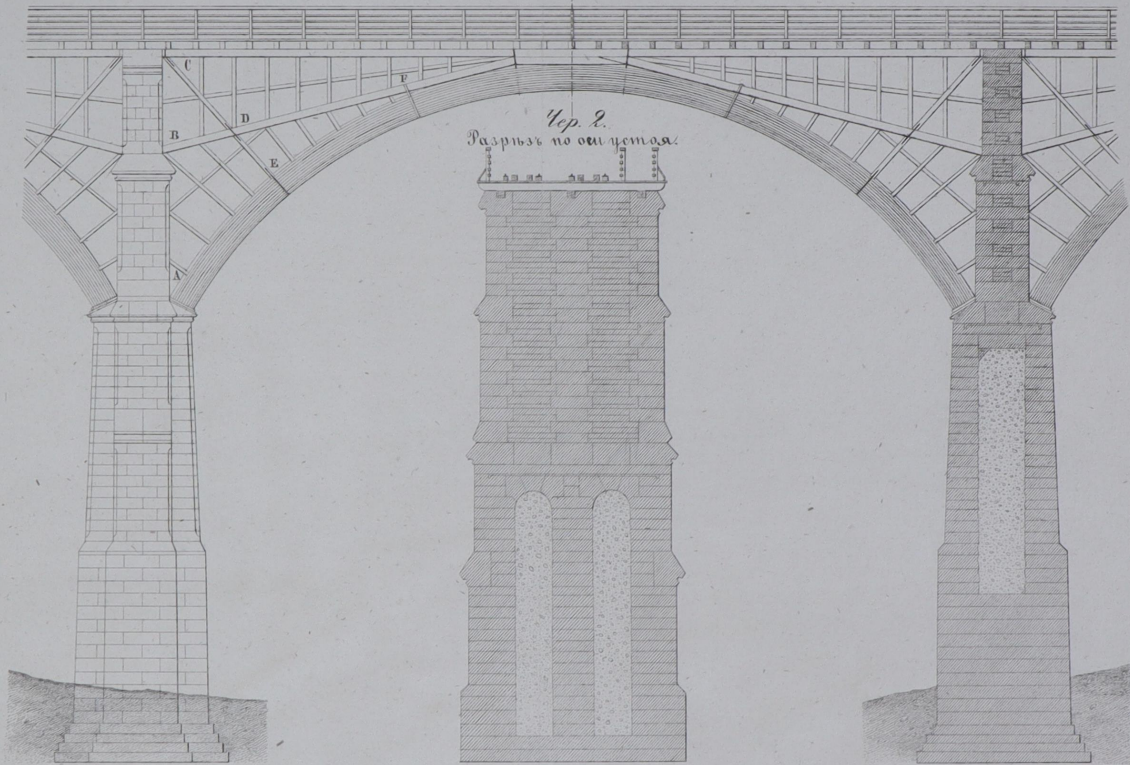

0 10 20 30 40 50 60 70 футовъ.

Чер. 2. Разрѣзь по оси устоя.

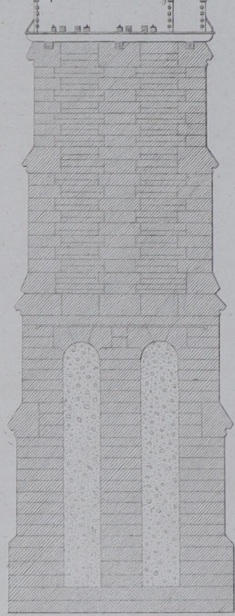

Фасадъ Чер. 3.

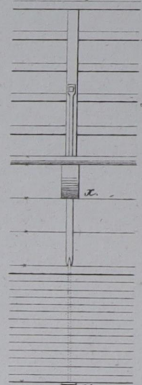

Чер. 7.

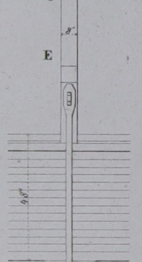

Чер. 10.

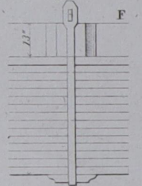

Детали:

Чер. 5.

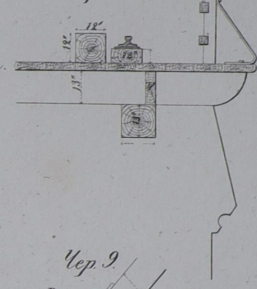

Разрѣзь Чер. 6.



Чер. 8. Видъ со стороны.

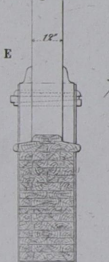

Чер. 11.



Чер. 9.

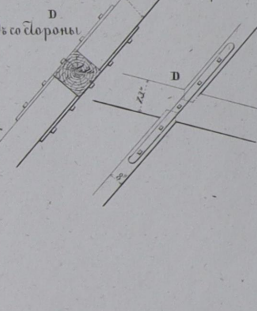

Чер. 12.



Чугунная коробка

Чер. 4.

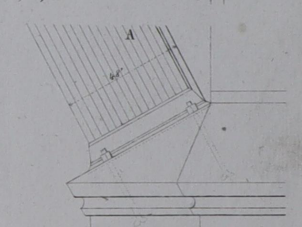
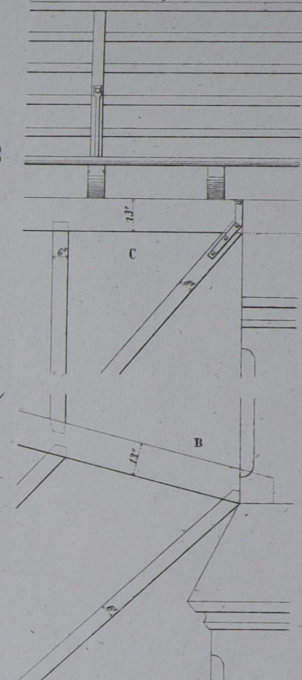

0 1 2 3 4 5 10 футовъ.

Чер. 1. Видъ съ боку.

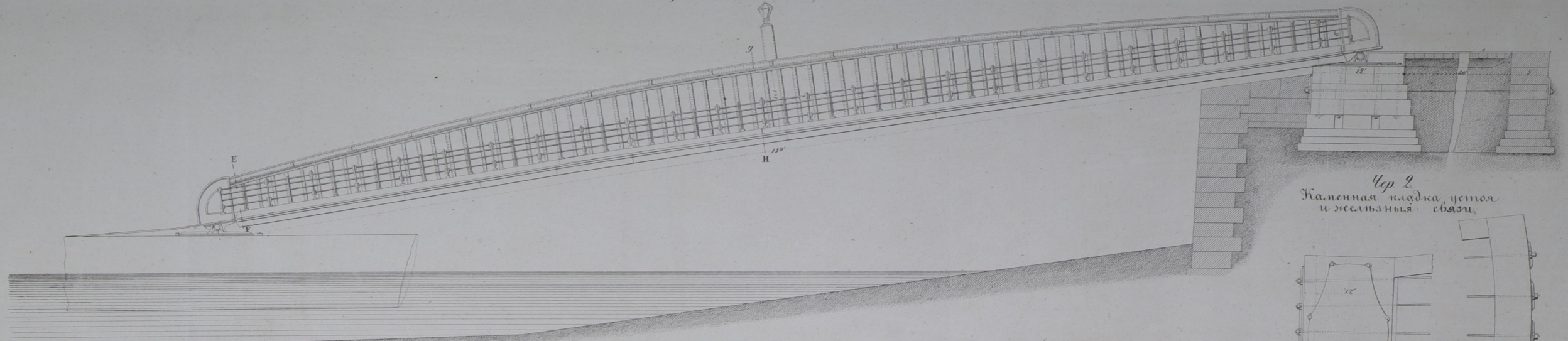

Чер. 2. Каменная кладка, цоколя и желѣзные сваи.

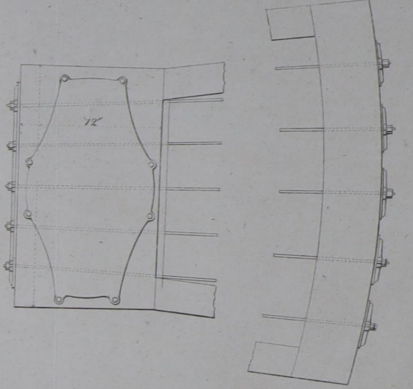

Разрѣзъ по Е.Ф.

Чер. 3.

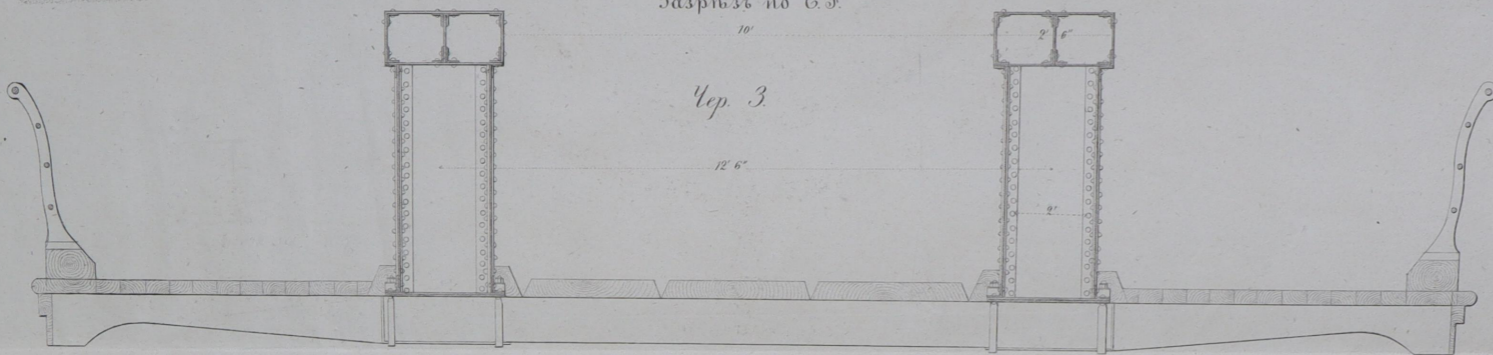

Основная доска и поворотный кругъ.

Чер. 6.

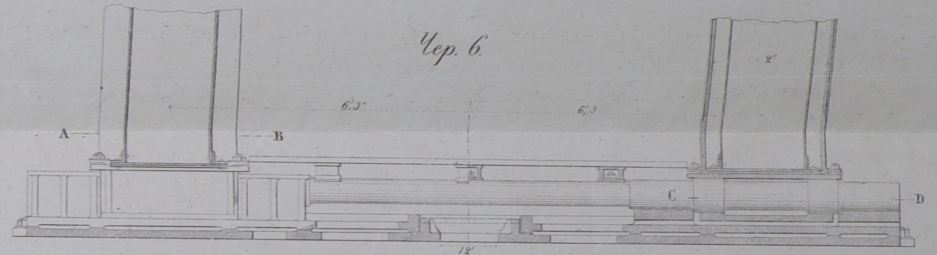

Чер. 5. Разрѣзъ по К.Л.



Разрѣзъ по Г.Н.

Чер. 4.

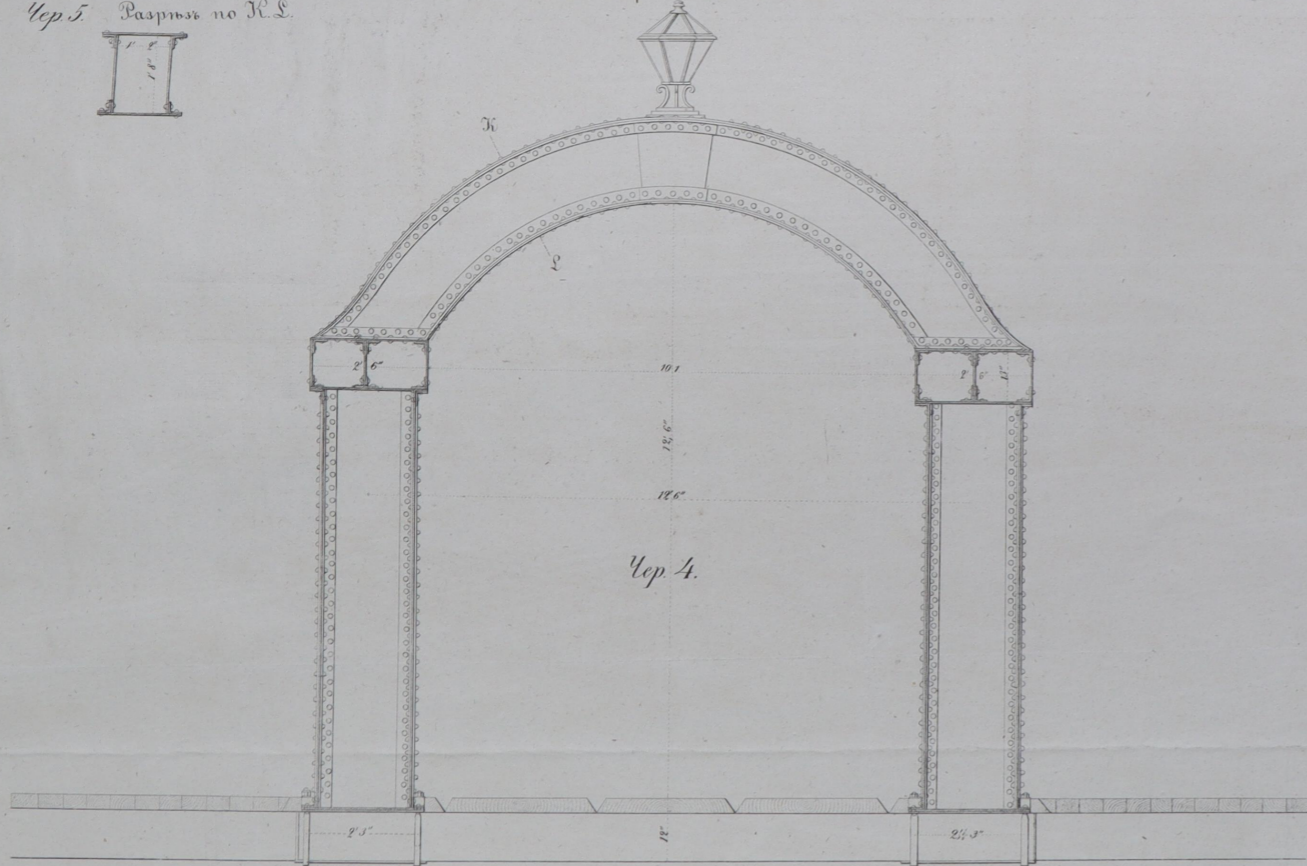

Планъ по А.В.

Чер. 7.

Планъ по С.Д.

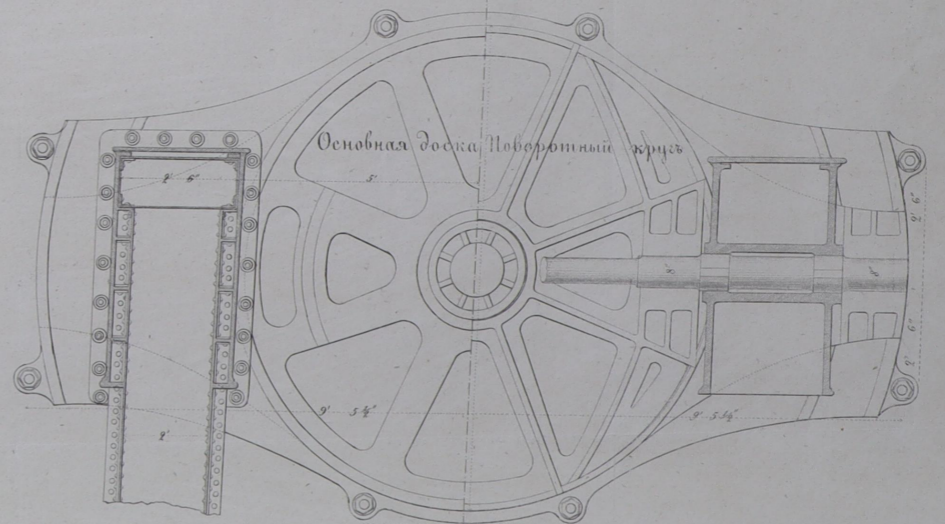

Къ Чер. 1 и 2.

Масштабы.

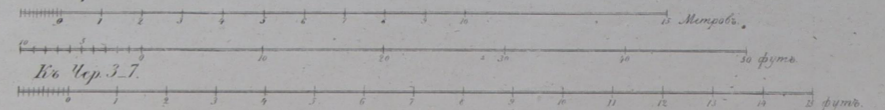

Чер. 1.

ГЕНЕРАЛЬНЫЙ ПЛАНЪ
железной дороги чрезъ
Землеринскій хребтъ, между
Клогницель и Мюрицшлагомъ.



Чер. 1.

Продольная профиль
Жельзной дороги чрезъ гору Зенлерингъ,
отъ Глогница до Мюрцишлага.

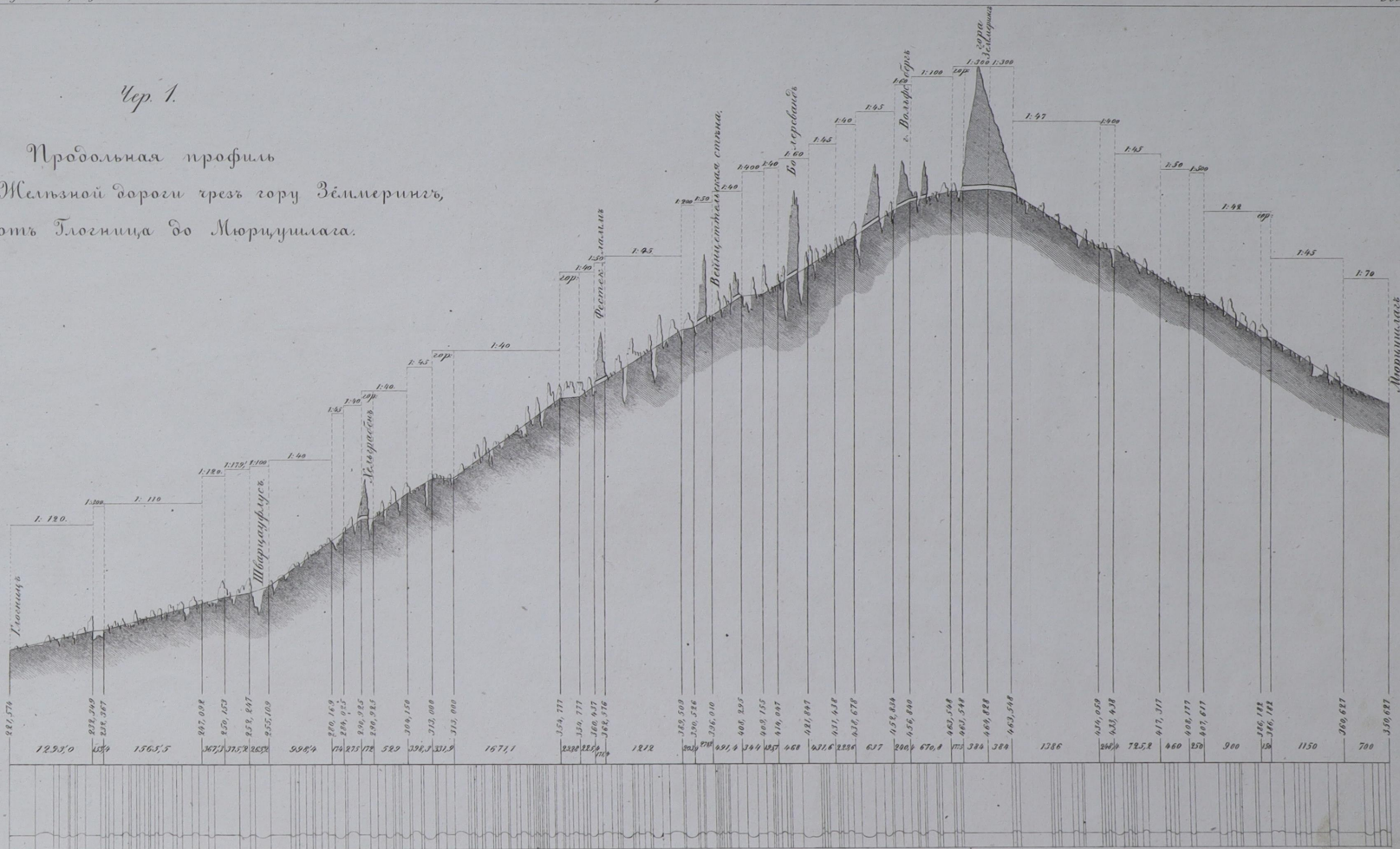

Чер. 14.

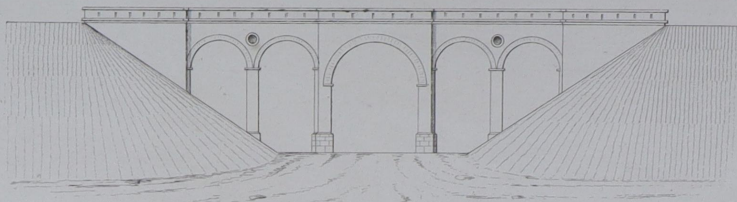

Чер. 14. (а)

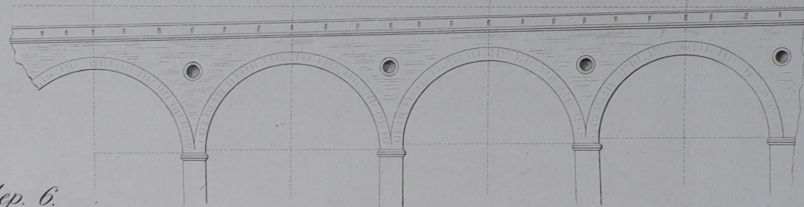

Чер. 5.

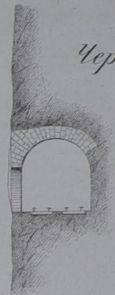

Чер. 15.

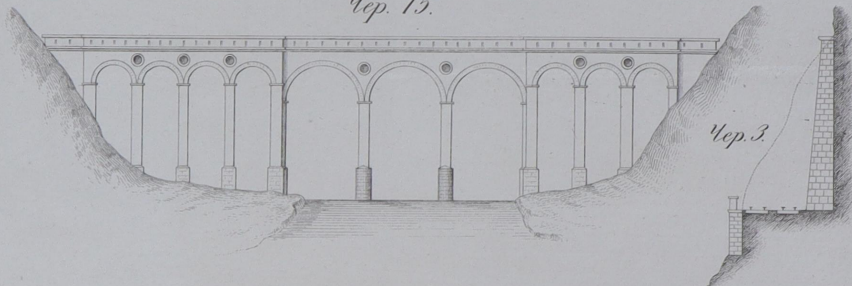

Чер. 3.

Чер. 6.

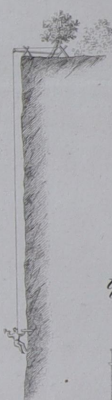

Чер. 21.



Чер. 8.

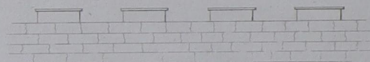

Чер. 10.

Разрѣзъ.

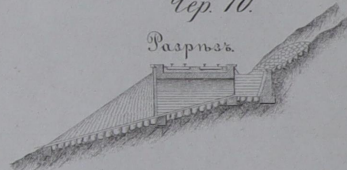

Чер. 16.

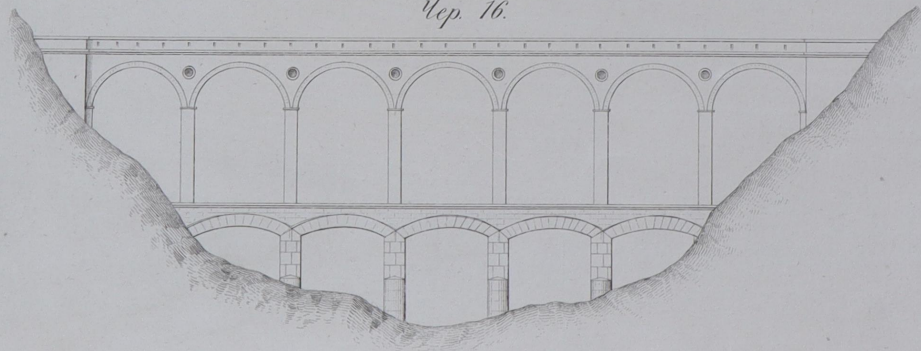

Чер. 4.



Чер. 22.

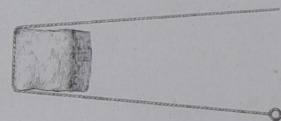
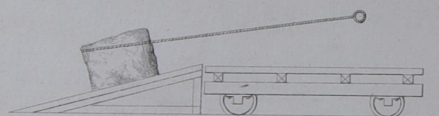

Планъ.

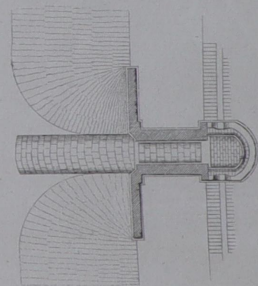

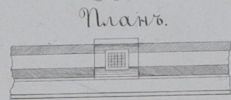
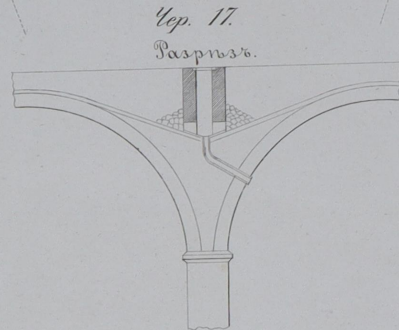
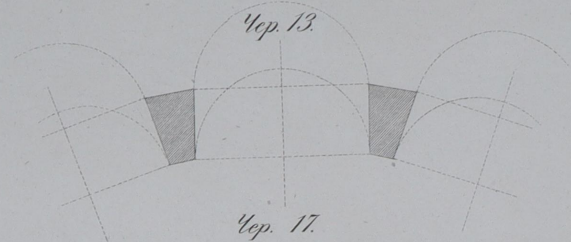

Чер. 11.

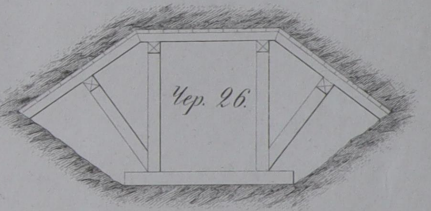
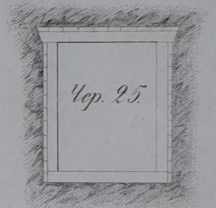
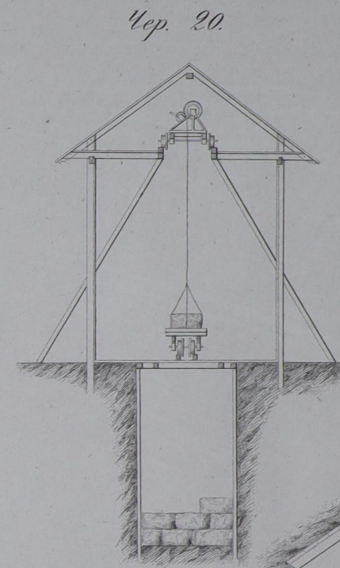
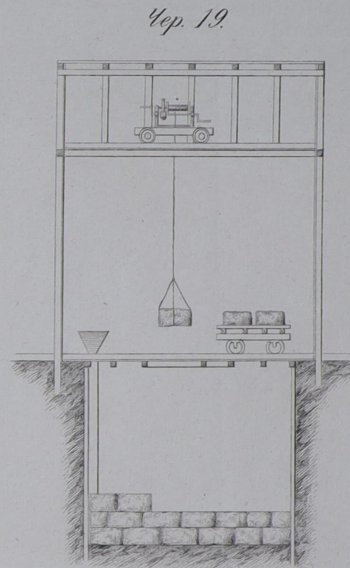
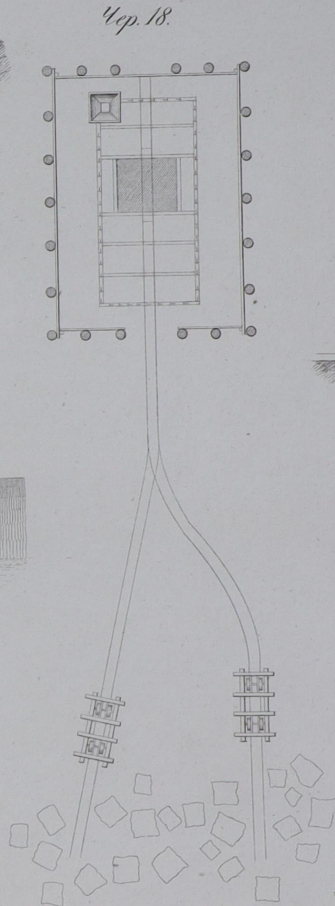
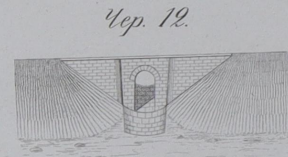
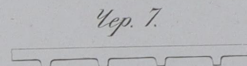
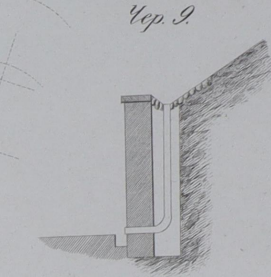
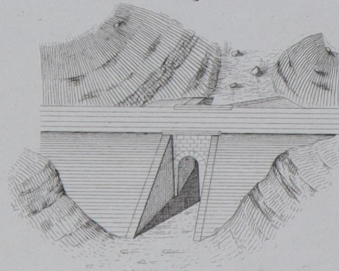

Чер. 23.

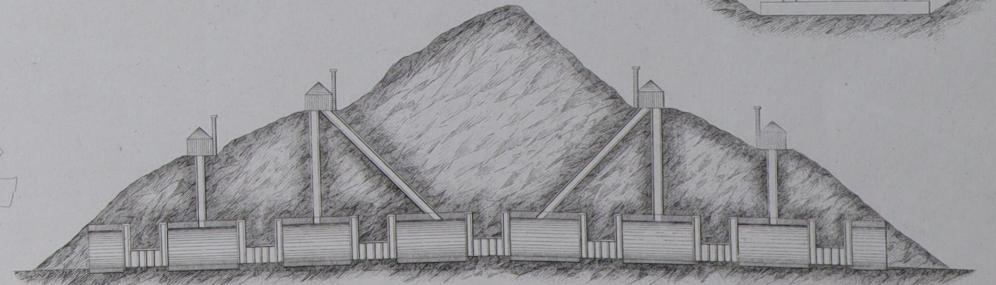

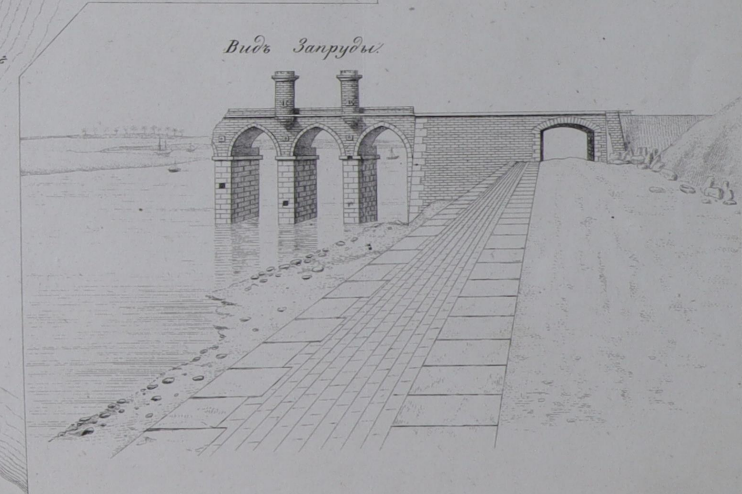
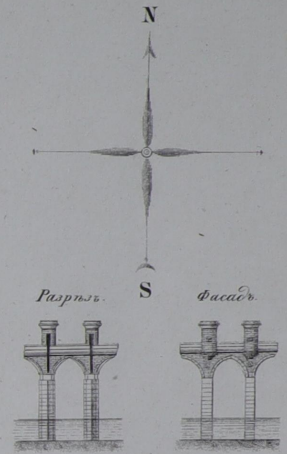
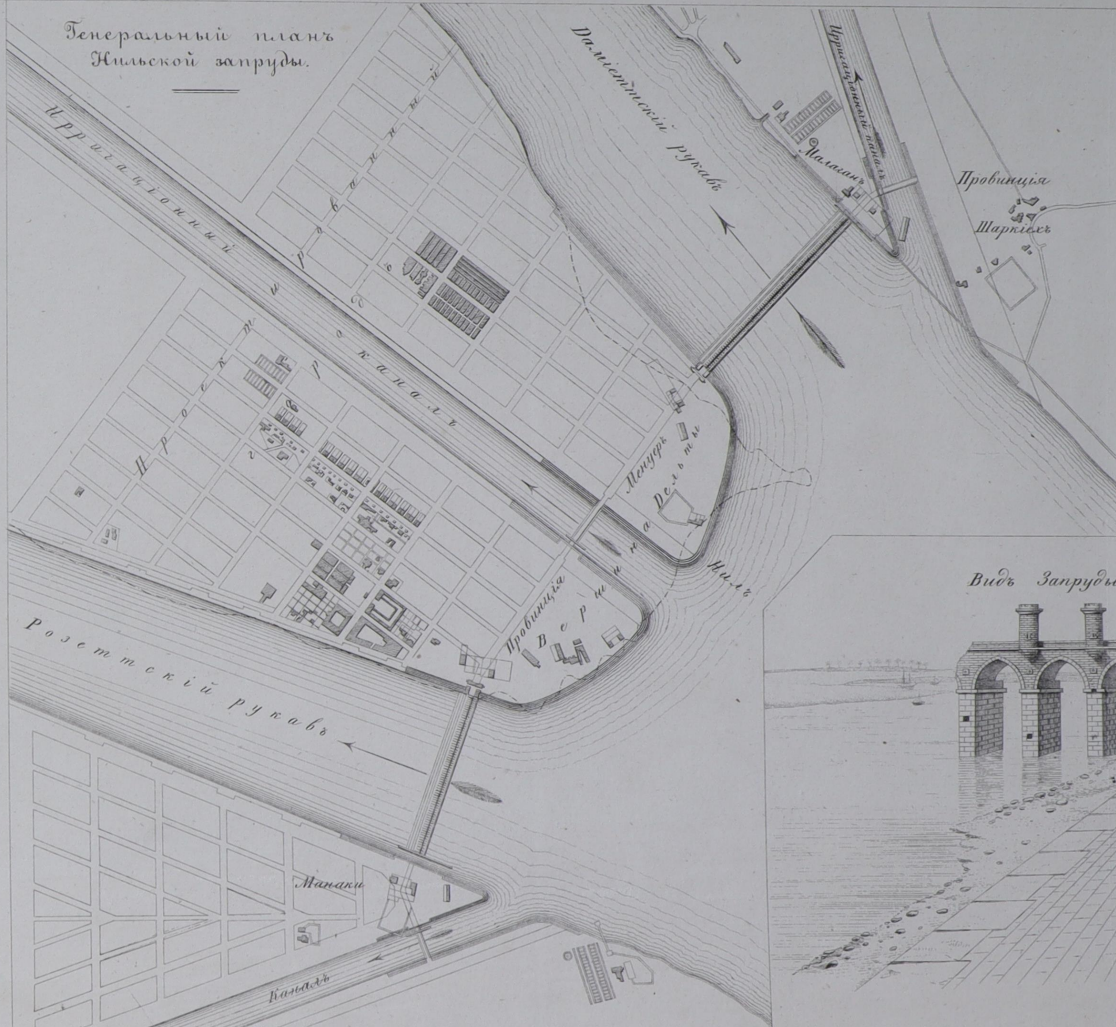

Карта Египта.

Генеральный план Нильской запруды.

Видъ Запруды.

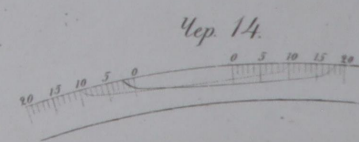
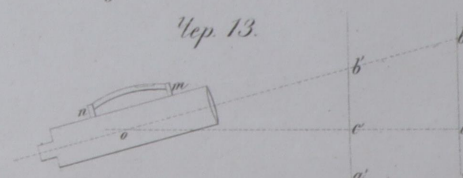
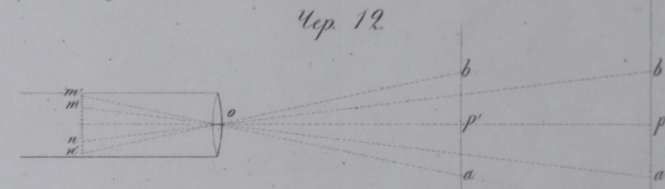
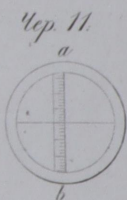
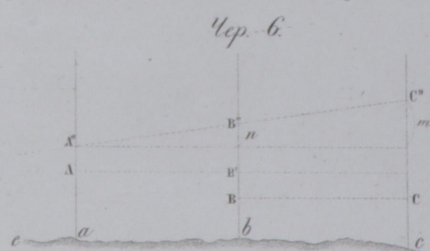
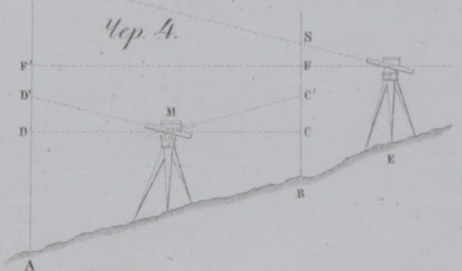
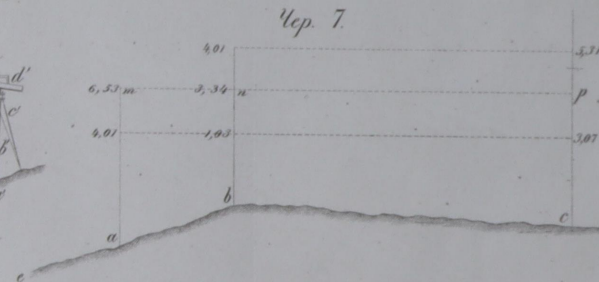
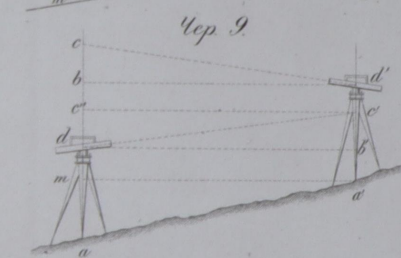
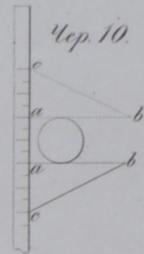
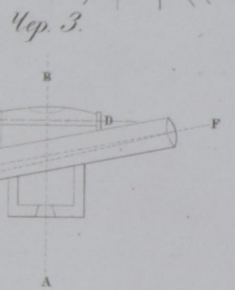
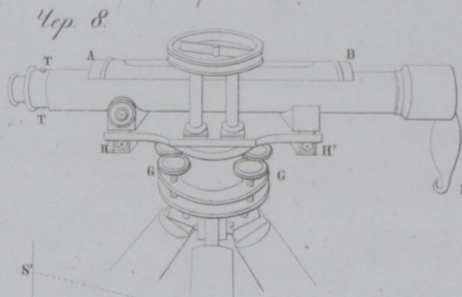
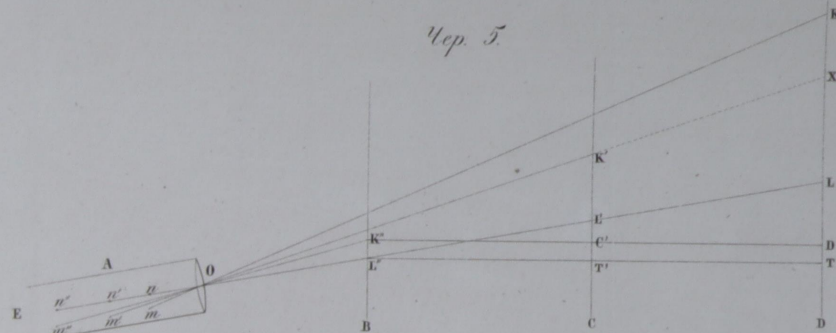
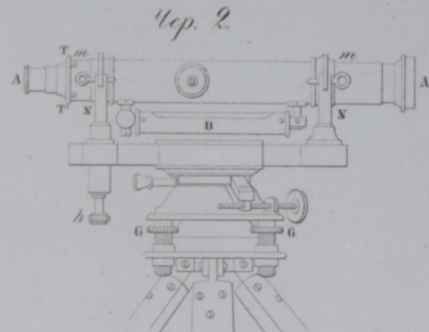
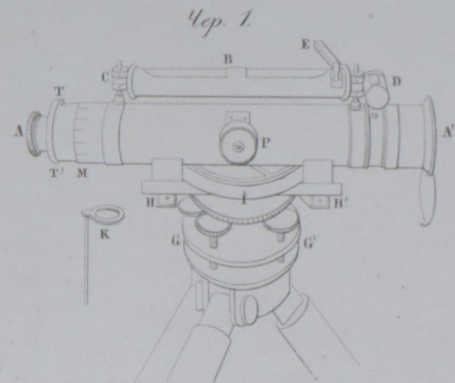

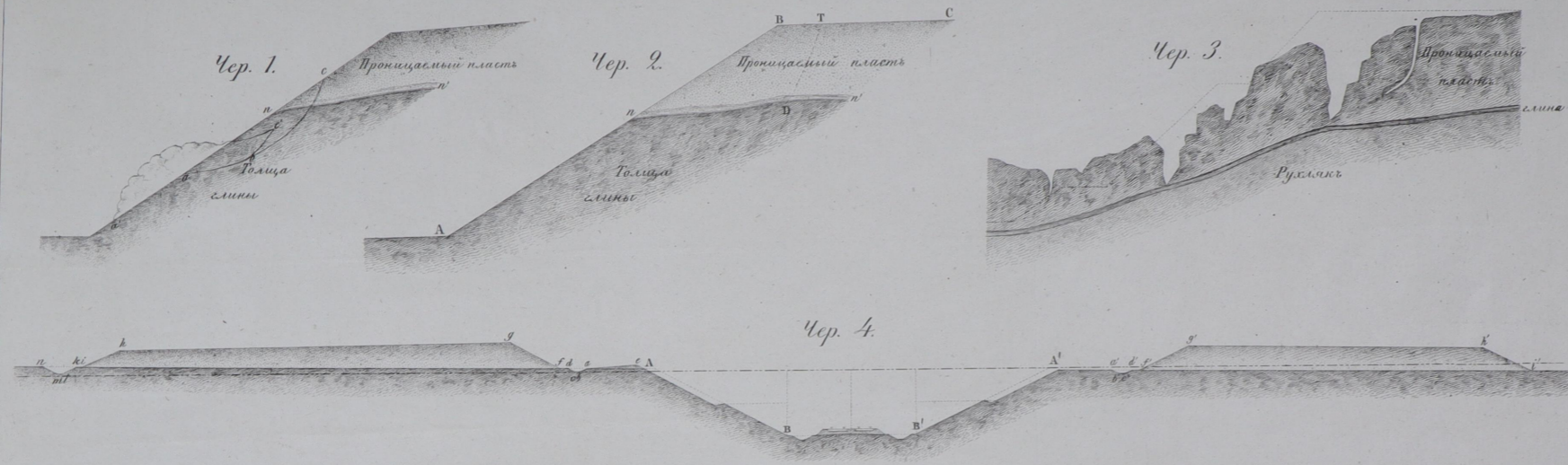

Чер. 5.

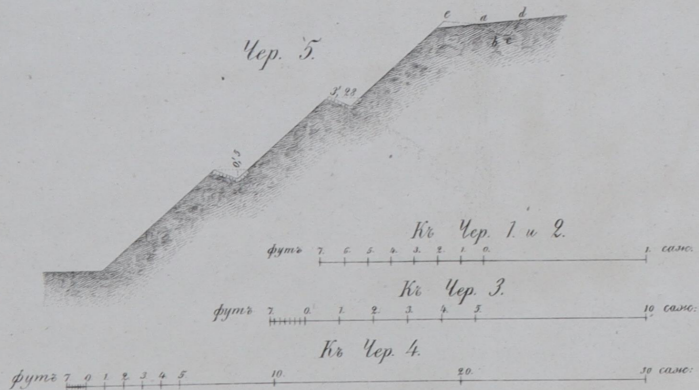

Къ статьѣ: Мостъ соединяющій въ себѣ систему висятую съ трубатою.

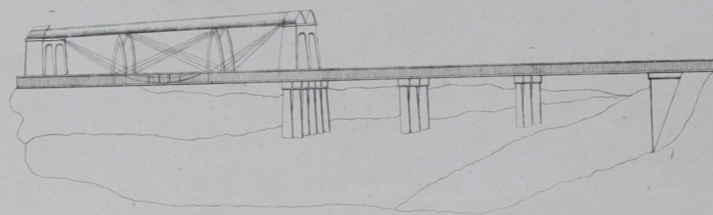

Къ статьѣ: Машины для тески камней, буренія скалъ и забивки свай.

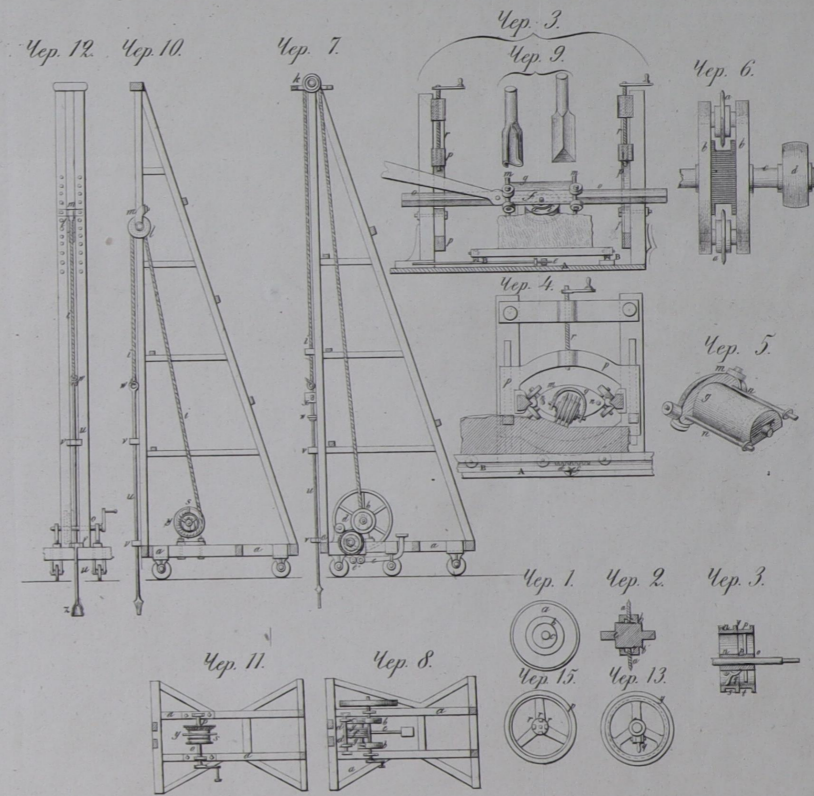

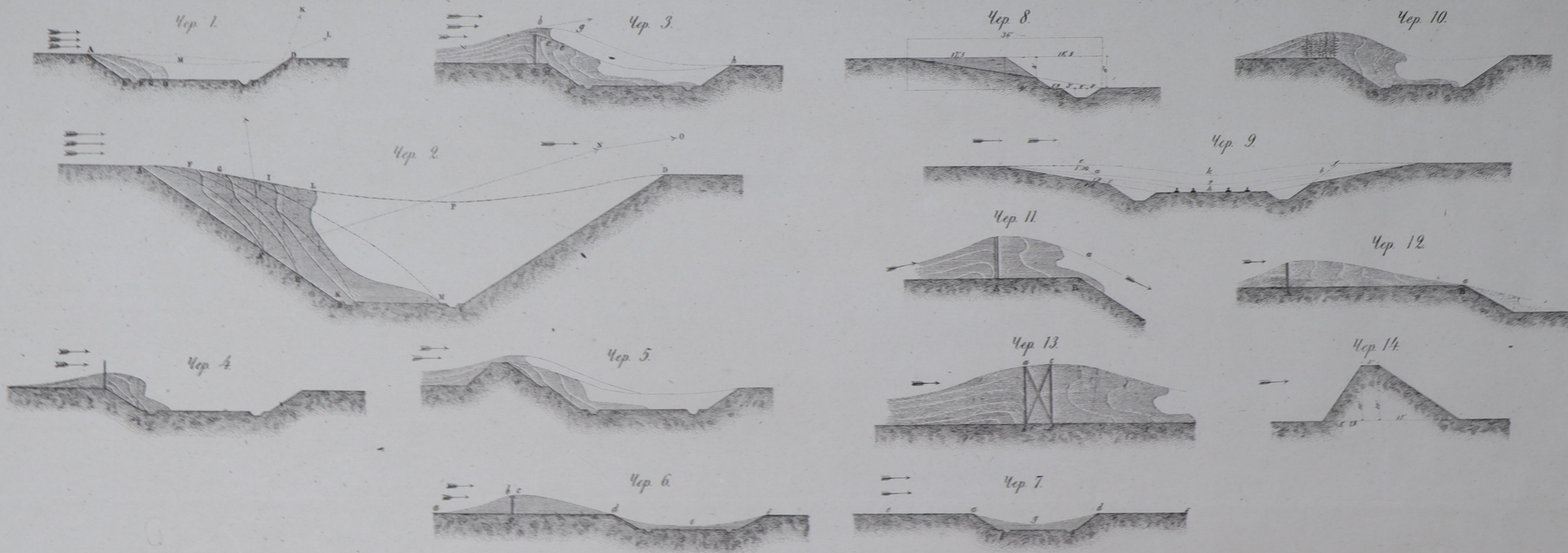

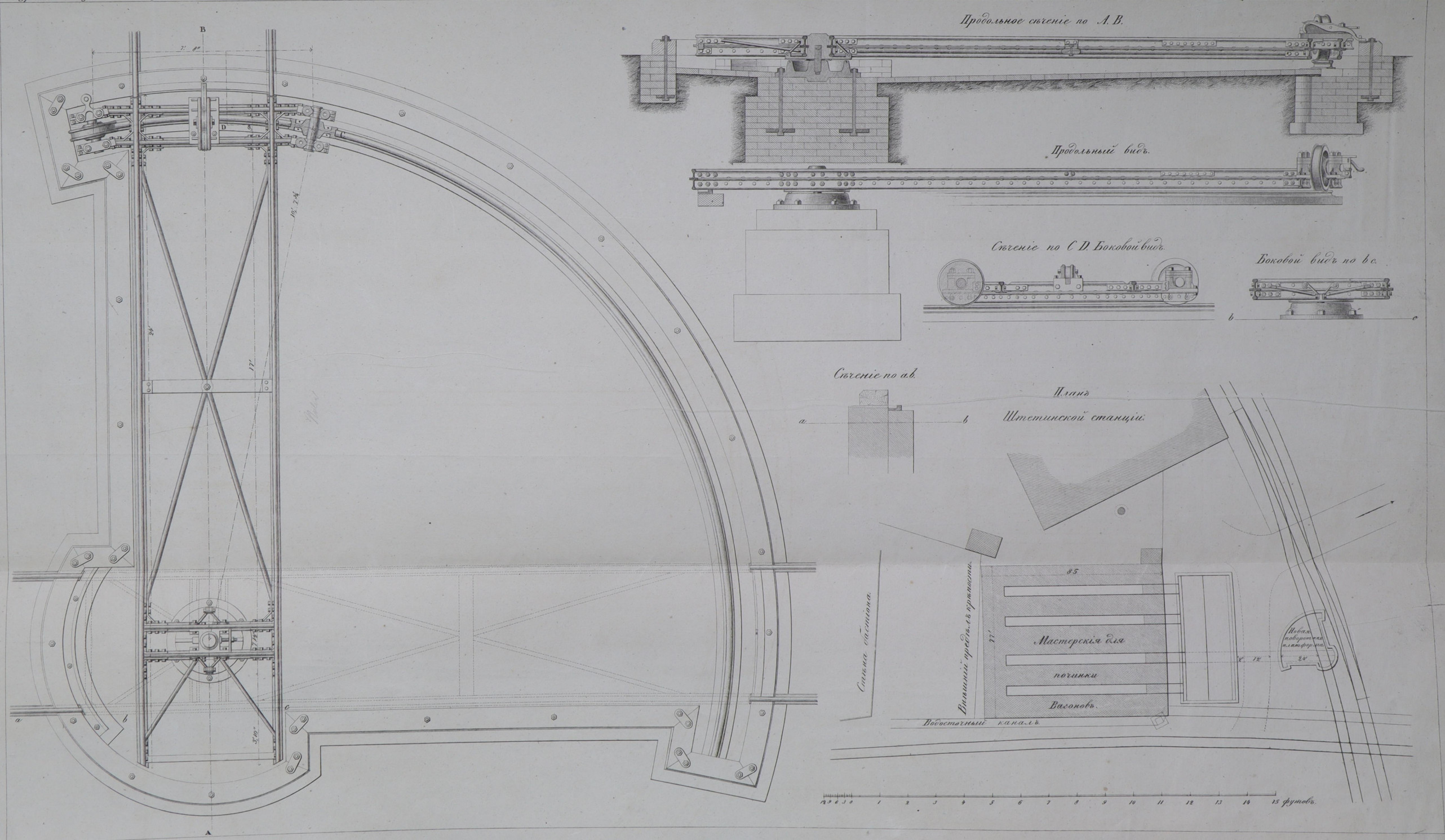

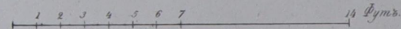
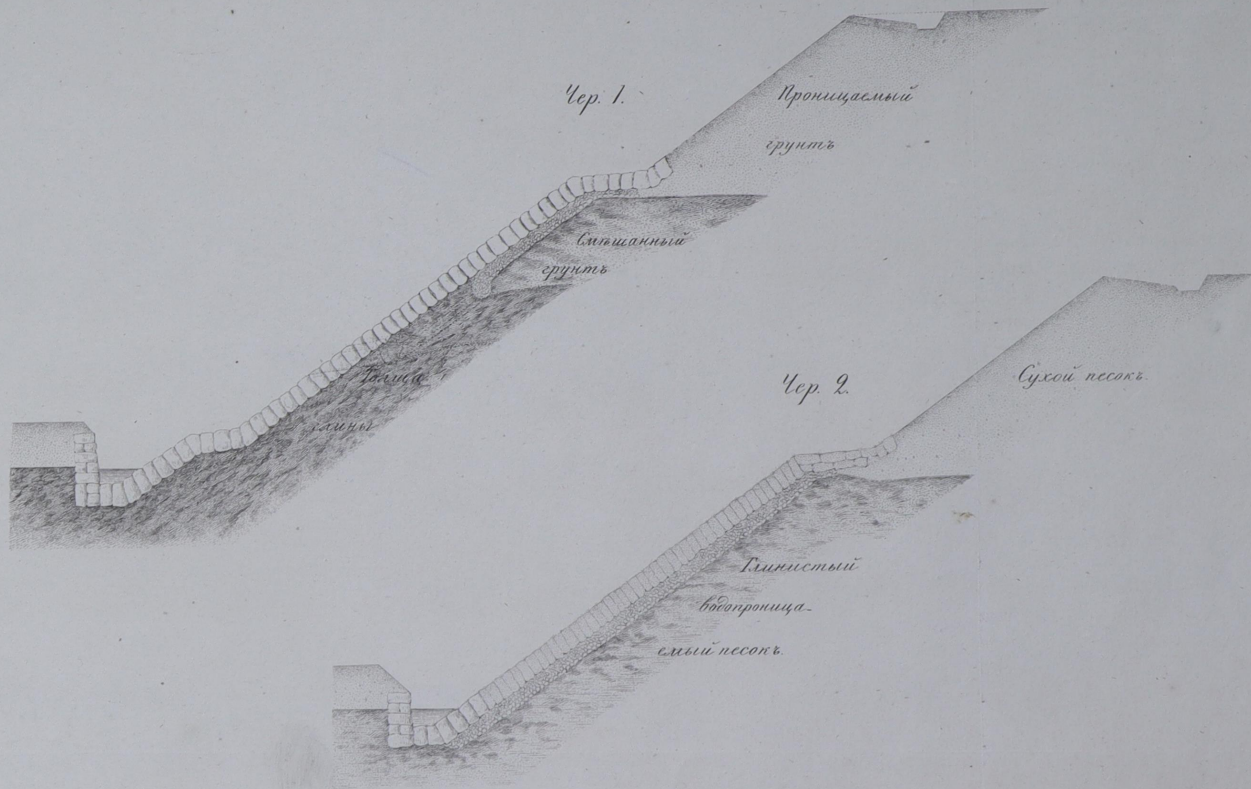

Чер. 1. Планъ обвалившагося откоса съ показаніемъ водопроницаемыхъ каменныхъ

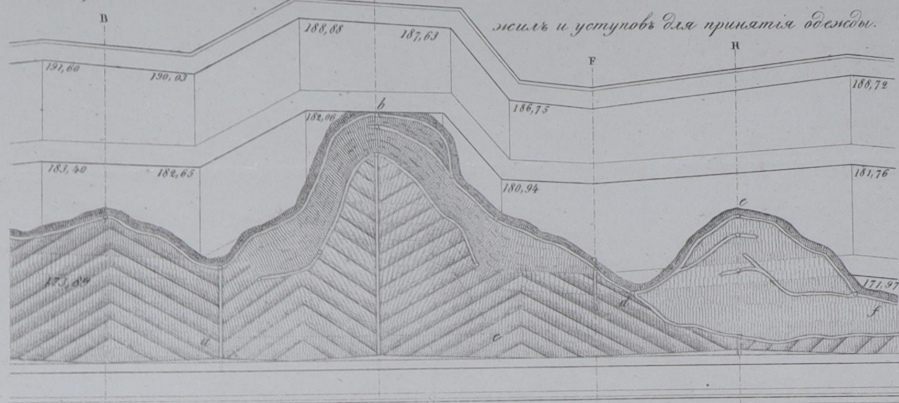

Чер. 2. Фасадъ откоса безъ обвалин съ показаніемъ уклоновъ водопроницаемыхъ каменныхъ земли и слоевъ грунта.

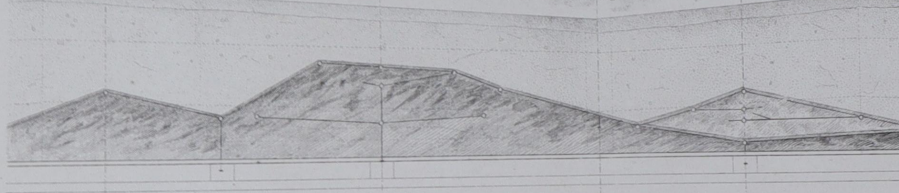

Разрѣзъ по А. В.

Чер. 4.

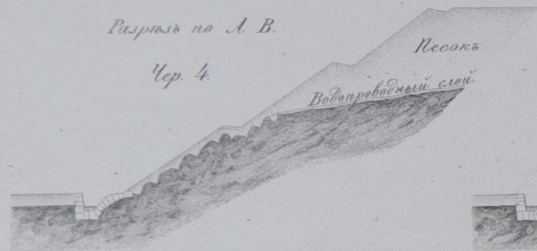

Разрѣзъ по С. Д.

Чер. 5.

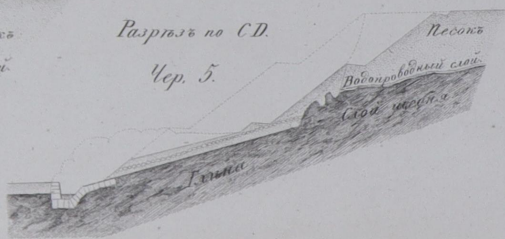

Чер. 3. Планъ обушки откоса.

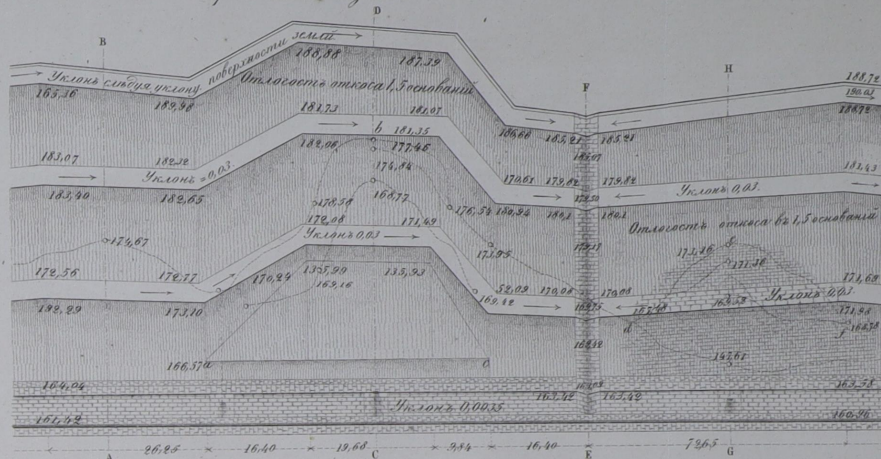

Разрѣзъ по Е. F.

Чер. 6.

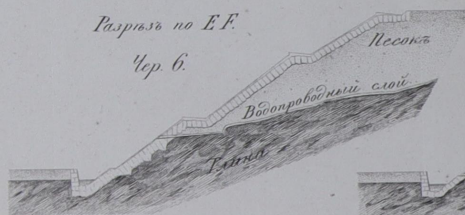

Разрѣзъ по Г. H.

Чер. 7.

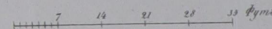
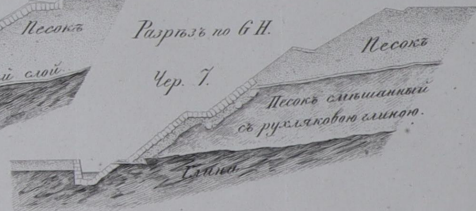

Механизмъ для выниманія и вкладыванія осей въ паровозахъ.

Чер. 1.
Разрѣзъ по А В.

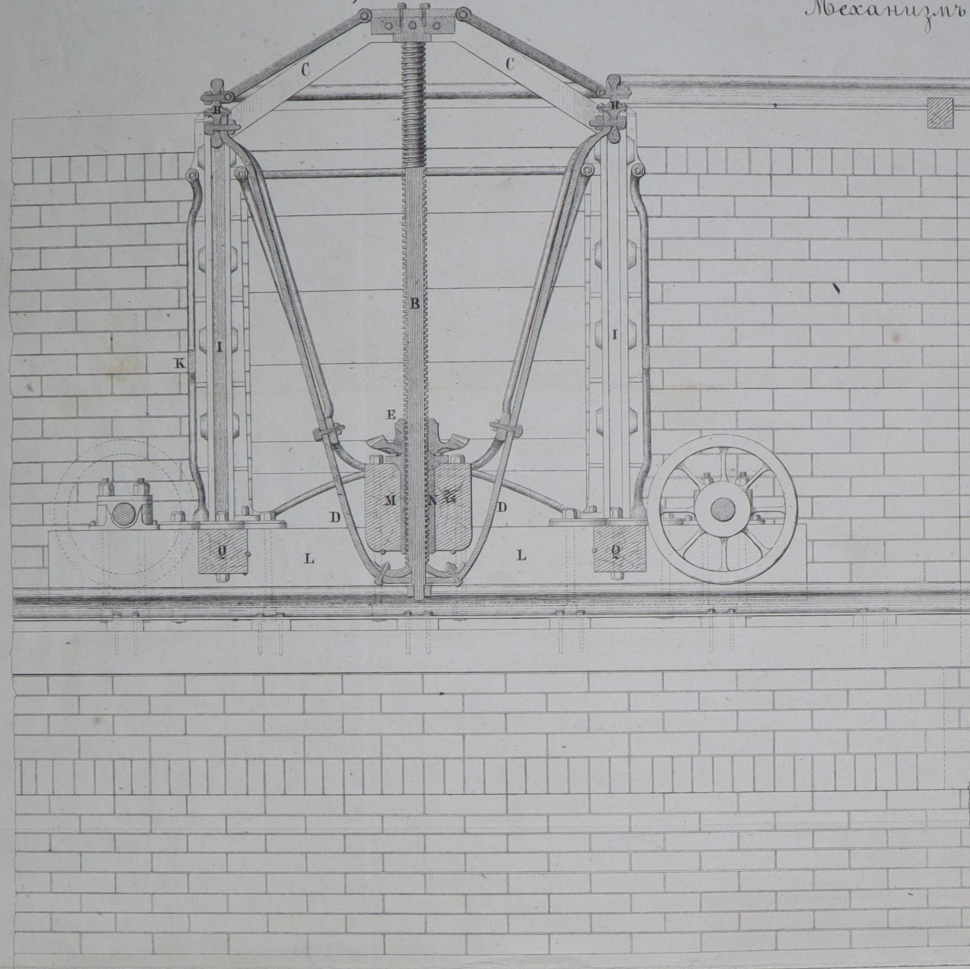

Разрѣзъ по С D.

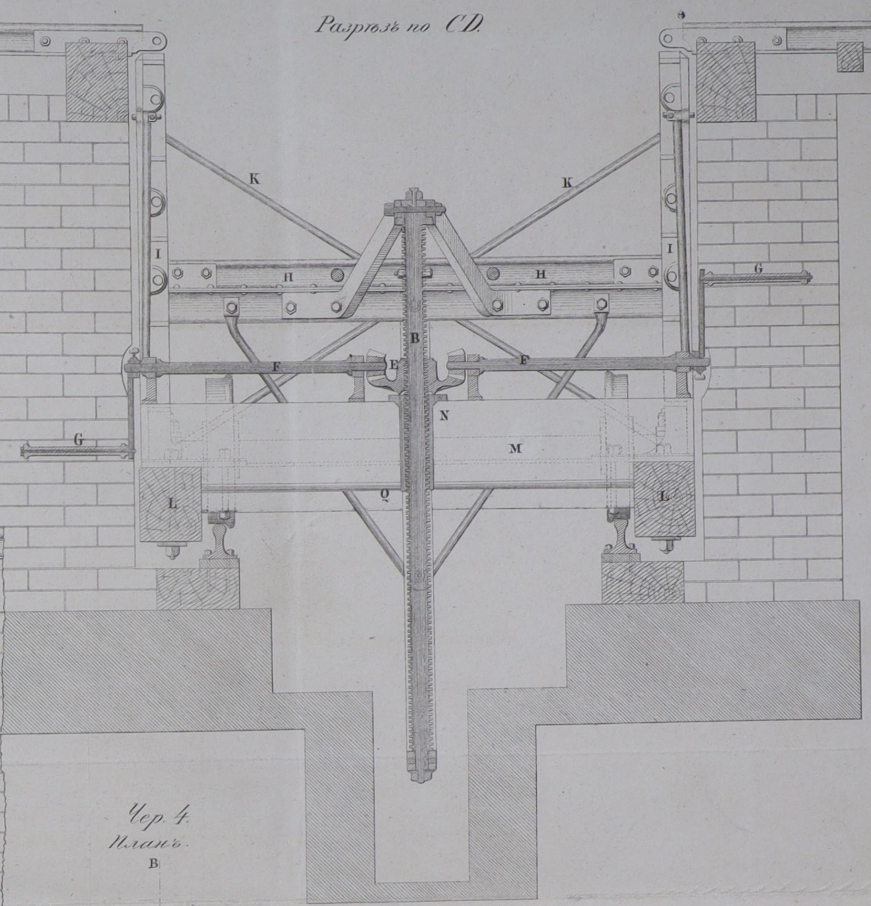

Чер. 2.

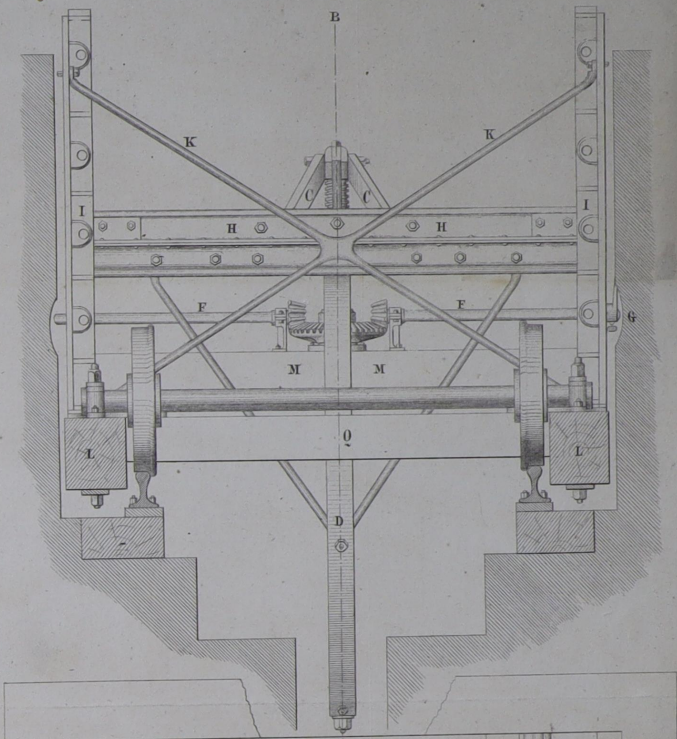

Чер. 4.
Планъ.
В

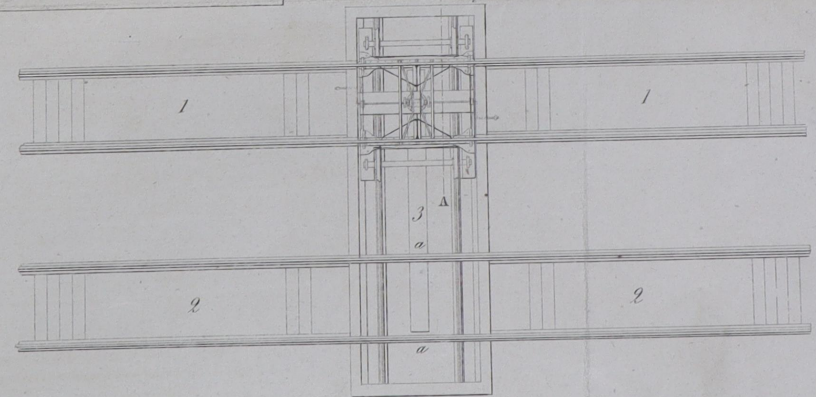

Мѣр. Чер. 1, 2, и 3.

0 1 2 3 4 5 6 футовъ.

Мѣр. Чер. 4.

0 1 2 3 4 5 6 7 8 9 10 11 12 футовъ.

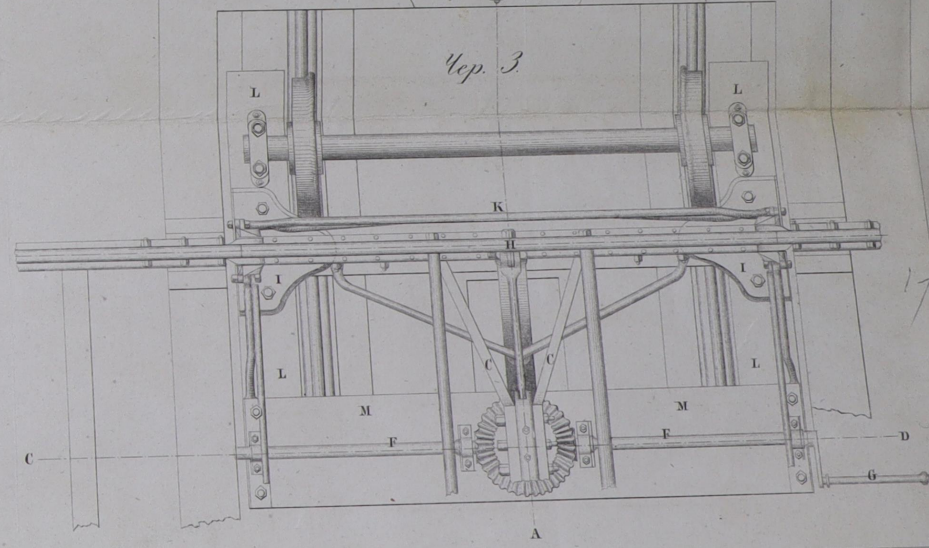

Чер. 1.

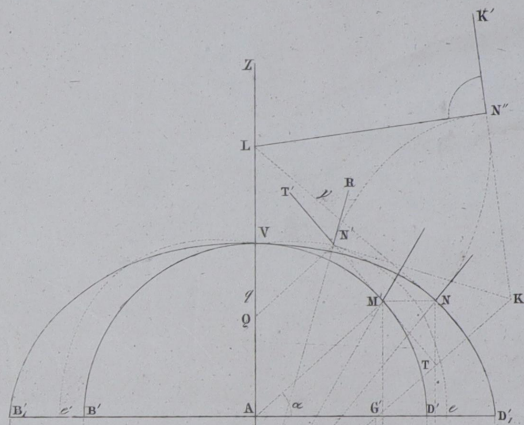

Чер. 2.

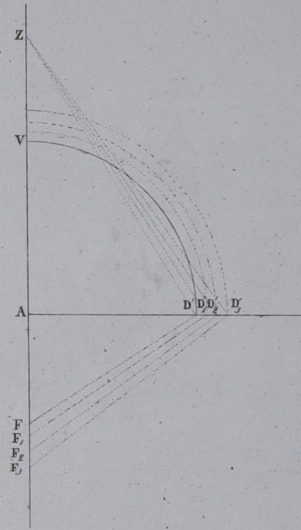

Чер. 3.

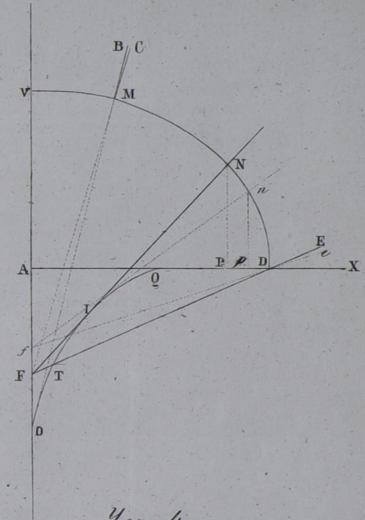

Чер. 4.

