

“

”

“

”

• •

,

• •

,

• •

,

• •

, • •

, • •

“

”

“

”

“

”

• • [] •

• •

• • •

•

• •

• • •

• • •

“

”

531.1 (075.8)
232

232

“ ”
/ ”
“ ”
; 2002.- 67 .
“ ”
“ ”
“ ”

	4
1.	5
2.	10
3.	15
4.	19
5.	25
6.	30
7.	35
8.	39
9.	43
10.	47
11.	51
12.	56
13.	60
	67

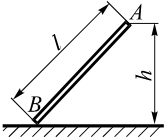
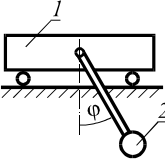
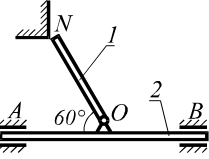
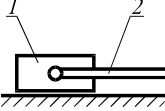
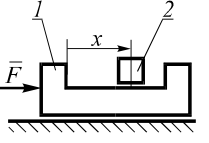
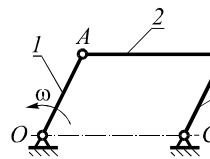
<p>1</p>  <p>h</p>	<p>2</p>  <p>m_1</p> <p>$\varphi = \varphi_0 \sin kt$</p> <p>$m_2$</p> <p>$l$</p>
<p>3</p>  <p>m</p> <p>60°</p> <p>2</p> <p>1</p> <p>$2,$</p> <p>$s.$</p>	<p>4</p>  <p>$3m,$</p> <p>$0,5$</p> <p>1</p> <p>$?$</p>
<p>5</p>  <p>$F = 20$</p> <p>$x = \cos t$</p> <p>$m_1 = 4$ $m_2 = 1$</p> <p>$t = 0,5$</p>	<p>6</p>  <p>1 3</p> <p>$= 5$</p> <p>ω</p> <p>$= 0,4$, $m_1 = m_3 = 5$,</p> <p>$m_2 = 8$</p>

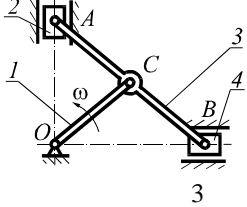
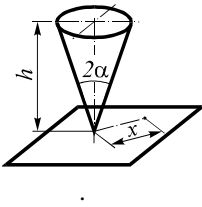
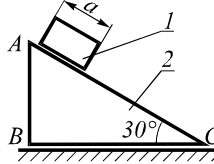
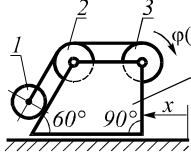
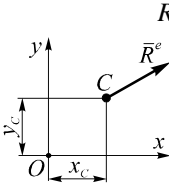
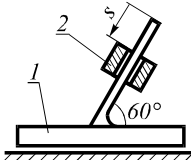
<p>7 1 0,5m</p>  <p>$l = l = l$</p>	<p>8 2 h</p>  <p>x</p>
<p>9 1 4 2, 20</p>  <p>$a = 10$</p> <p>$m = 20$</p> <p>$k = 100$</p>	<p>10 4 6</p>  <p>$m = 0,3$</p> <p>$x(t)$</p> <p>$t = 0$</p> <p>$x_0 = 0$</p>
<p>11</p>  <p>$\vec{R}^e = 3\vec{i} + 6t\vec{j}$</p> <p>$m = 20$</p> <p>$y_C = 0,8$</p>	<p>12 1 m_1 2 m_2</p>  <p>$s = 0,1 \sin 4t$</p> <p>t</p>

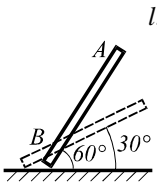
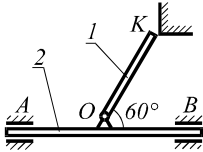
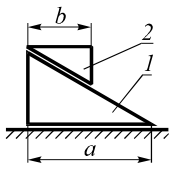
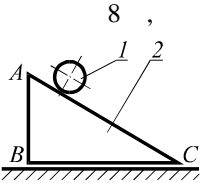
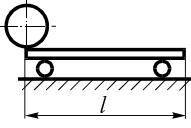
<p>13</p>  <p>l</p> <p>$\varphi_0 = 60^\circ$</p> <p>$\varphi = 30^\circ$</p>	<p>14</p> <p>$m = 30$</p> <p>$m_1 = 70$</p> <p>$m_2 = 90$</p> <p>$l_1 = 1$</p> <p>$l_2 = 0,5$?</p>
<p>15</p>  <p>5</p> <p>0,6</p> <p>10</p> <p>2</p> <p>1</p> <p>K</p> <p>2</p> <p>1</p>	<p>16</p>  <p>1,</p> <p>2.</p> <p>1</p> <p>2.</p> <p>2</p> <p>1,</p>
<p>17</p>  <p>8</p> <p>100</p> <p>$= 120$</p> <p>16</p> <p>$= 50$</p>	<p>18</p>  <p>12</p> <p>14</p> <p>3</p>

<p>19</p> <p>$\varphi = 2t$</p> <p>$m = 4$</p> <p>$= 0,6$</p>	<p>20</p> <p>$x = t^2$</p> <p>$m_1 = 4$, $m_2 = 1$</p>
<p>21</p> <p>$h = 60$</p> <p>$= 45^\circ$</p>	<p>22</p> <p>$m_1 = 4$ $m_2 = 16$ m_4</p> <p>$h = 10$</p>
<p>23</p> <p>$m_1 = 20$ $m_2 = 10$</p> <p>$m = 100$</p>	<p>24</p> <p>$\varphi_0 = 60^\circ$</p> <p>$m_1 = 10$; $m_2 = 2$,</p> <p>$l = 0,6$</p> <p>$\varphi = 90^\circ$</p>

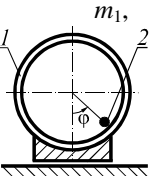
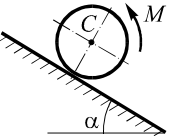
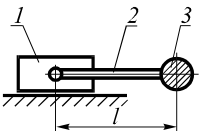
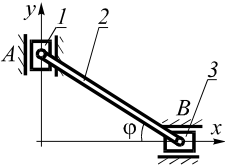
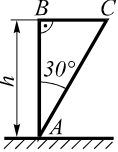
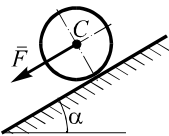
<p>25</p>  <p>1, 2, m_1, m_2.</p> <p>$v_0 = 0$,</p>	<p>26</p>  <p>α,</p> <p>f.</p>
<p>27</p>  <p>1, 2, 3, m_1, m_2, m_3.</p> <p>l, 1.</p>	<p>28</p>  <p>1, 3, $m_1 = m_3 = 2$,</p> <p>2, $m_2 = 4$, $l = 0,8$.</p> <p>$\phi = \pi t$.</p> <p>$t = 0,25$.</p>
<p>29</p>  <p>h, 30°,</p> <p>x,</p>	<p>30</p>  <p>F,</p> <p>$\alpha = 30^\circ$,</p> <p>$F = 4 fP$, $P -$, f,</p>

2

$v_0,$ $t_0 = 0,$
 1 $m_1,$
 2 $m_2.$
 $s = f_1(t)$ $\varphi = f_2(t).$

$t_1.$

1.

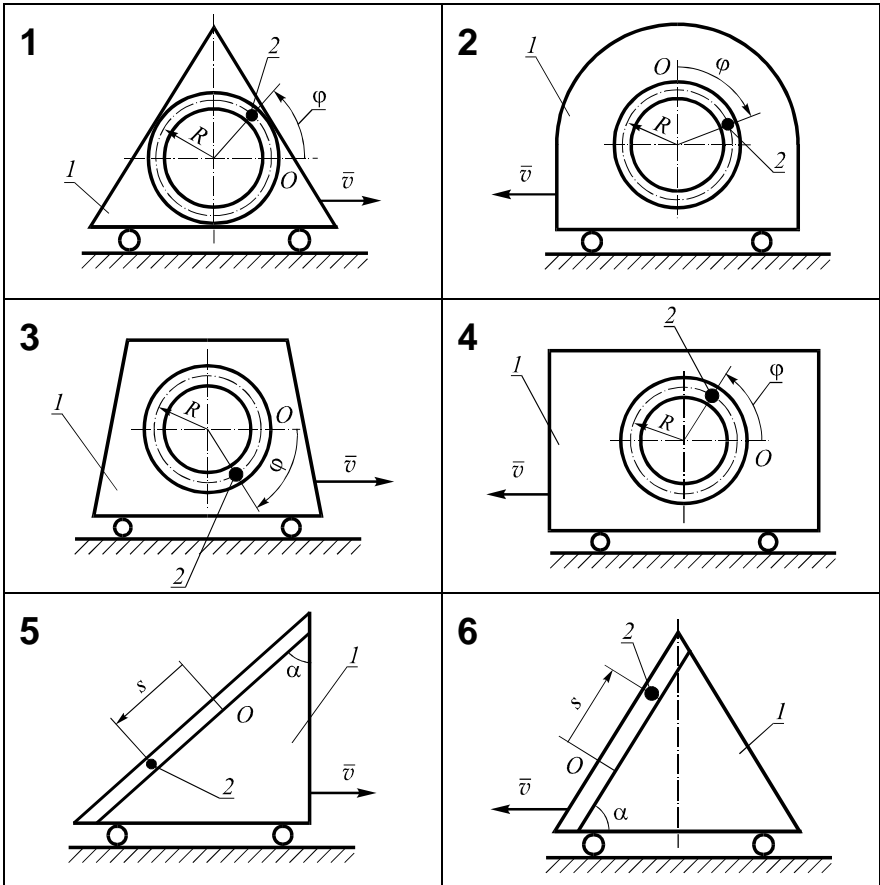

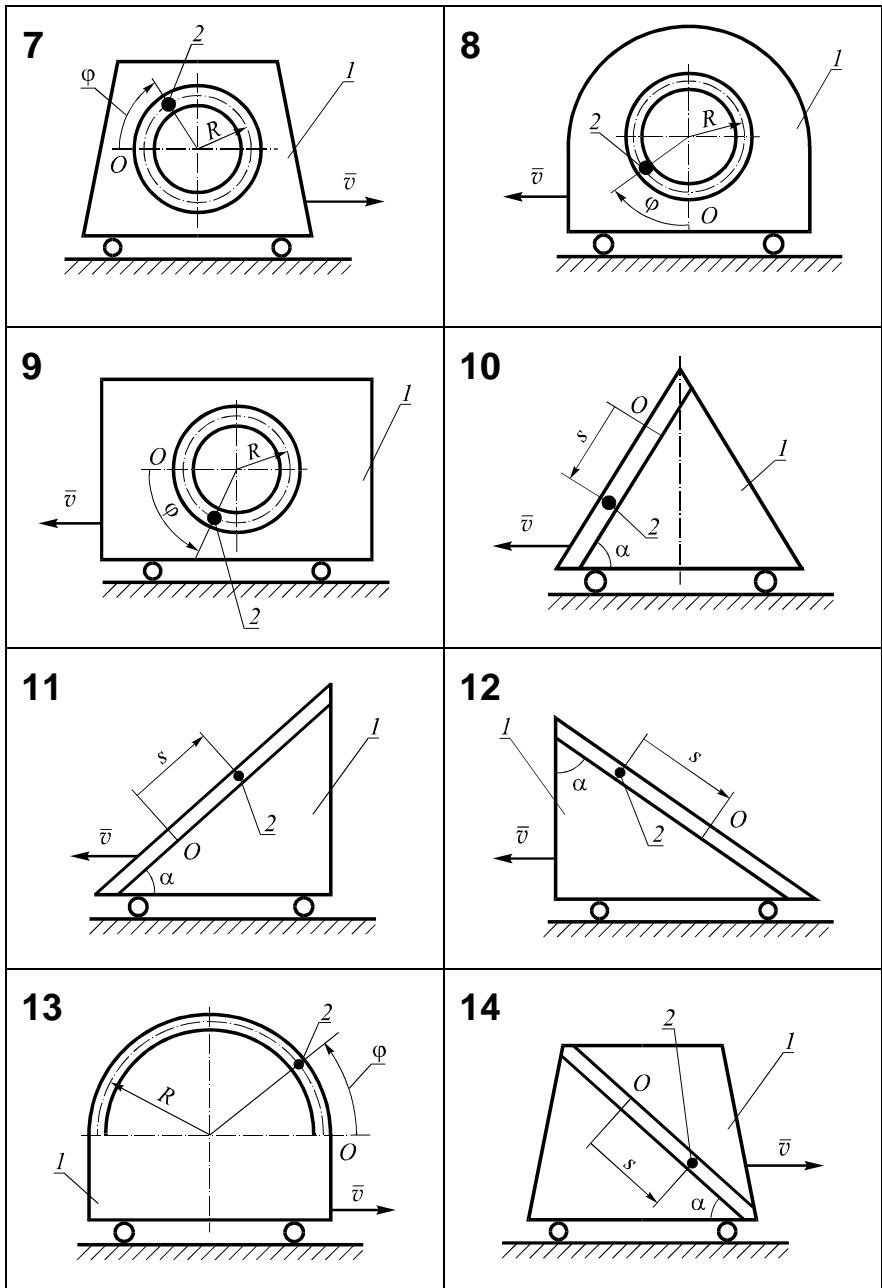

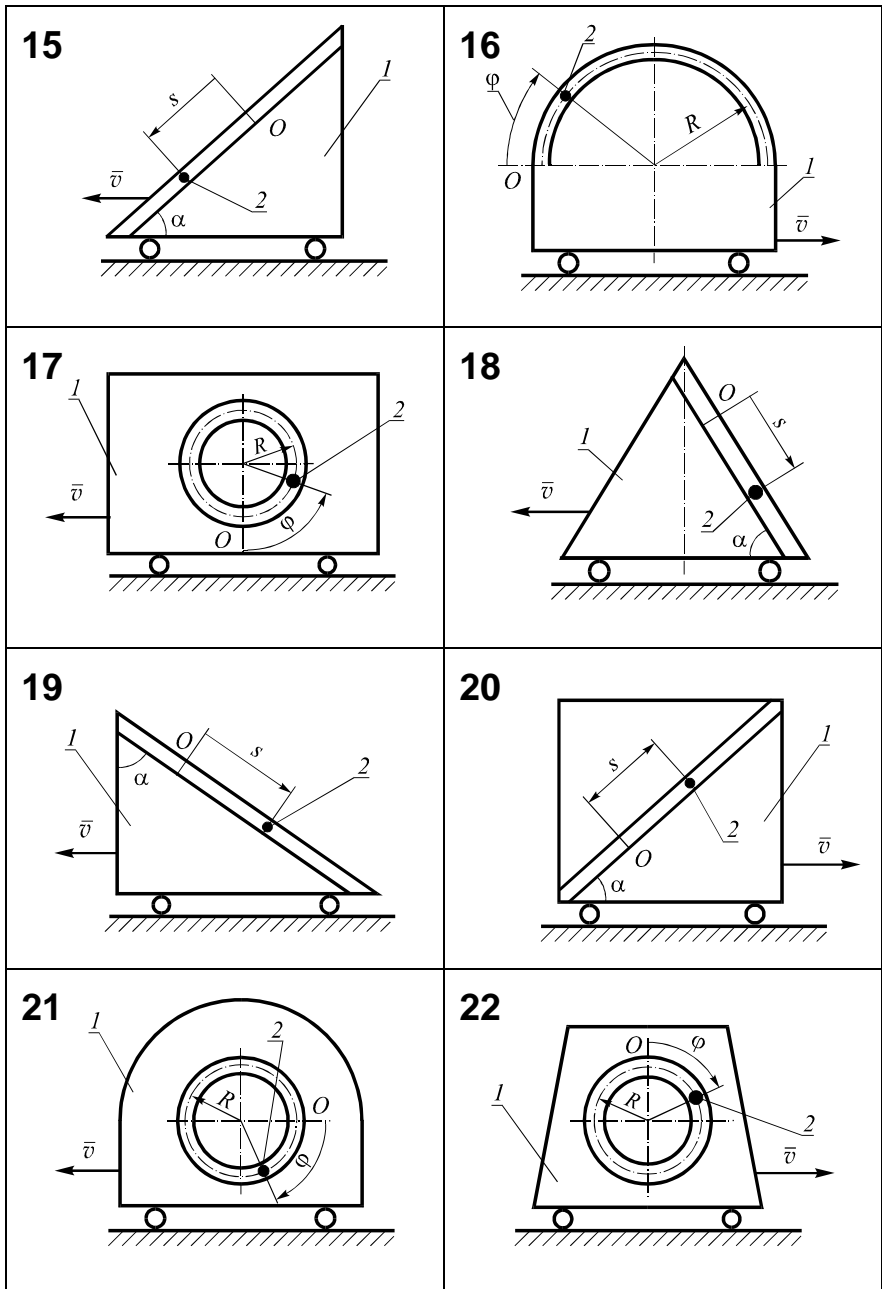

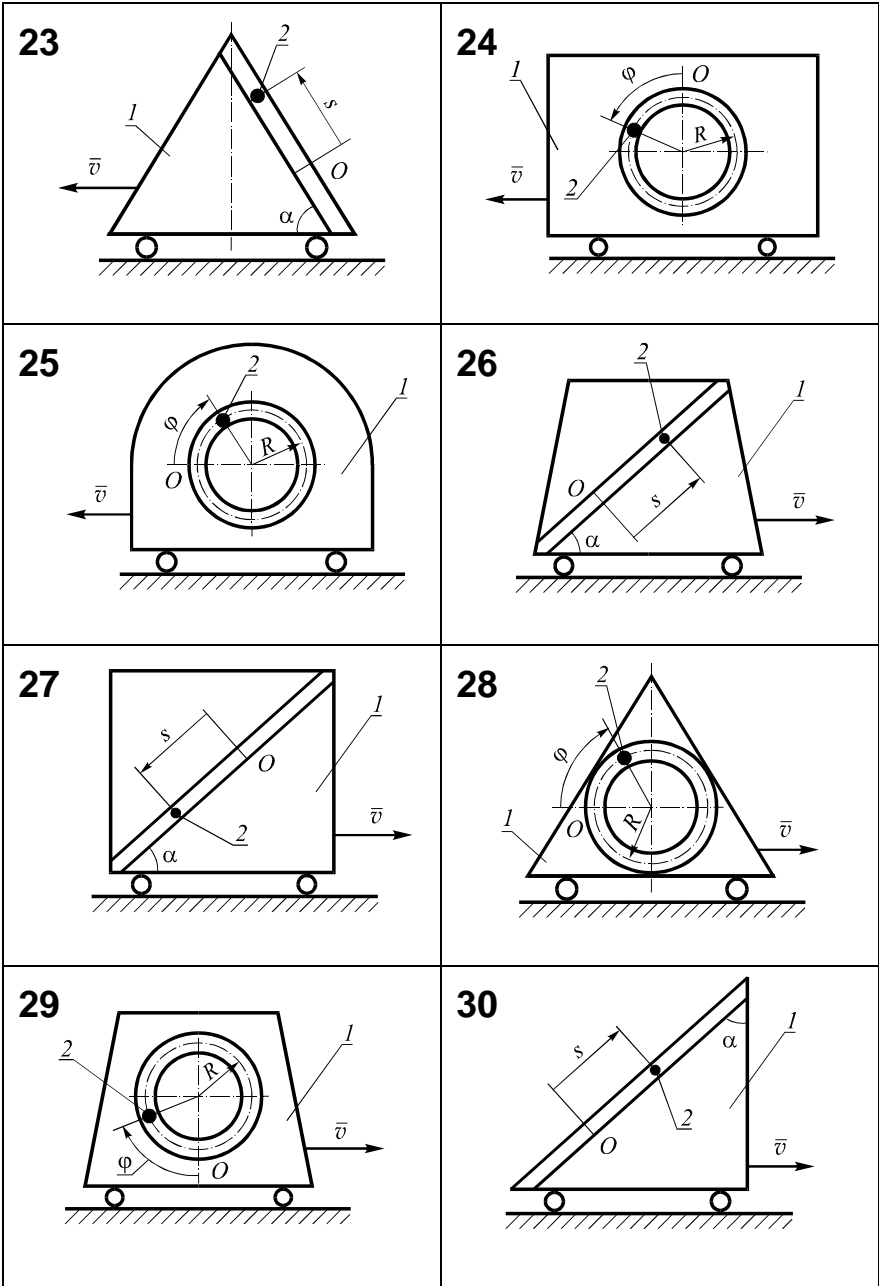

	m_1 ,	m_2 ,	v_0 , /c	t_1 , c	α ,	R ,	$s = f_1(t)$,	$\varphi = f_2(t)$,
1	31	13	3	6	–	2	–	$\sin(\pi t / 6)$
2	86	43	2	2	–	4	–	$5 \cos(\pi t / 4)$
3	20	10	1	1	–	3	–	$2 \sin(\pi t / 4)$
4	70	35	3	2	–	3	–	$4 \sin(\pi t / 2)$
5	63	41	1	3	45	–	$1 - t^2$	–
6	36	16	3	2	60	–	$3t^2 - 4$	–
7	60	25	3	2	–	5	–	$\sin(\pi t / 2)$
8	66	28	4	3	–	2	–	$\cos(\pi t / 3)$
9	45	18	5	4	–	1	–	$\sin(\pi t / 4)$
10	28	14	2	1	45	–	$2 - 6t^2$	–
11	73	42	2	2	60	–	$6t^2 - 5$	–
12	15	6	3	2	60	–	$5t^2 - 1$	–
13	56	23	5	1	–	1	–	$3 \sin(\pi t / 3)$
14	80	30	4	2	30	–	$3 - t^2$	–
15	53	29	3	2	60	–	$7t^2 - 3$	–
16	42	19	4	1	–	2	–	$6 \cos(\pi t / 3)$
17	65	32	4	2	–	2	–	$\cos(\pi t / 2)$
18	26	9	2	3	60	–	$5t^2$	–
19	30	12	4	1	30	–	$4 - 2t^2$	–
20	47	27	4	1	45	–	$10t^2 - 6$	–
21	76	33	3	3	–	3	–	$\sin(\pi t / 3)$
22	40	20	2	4	–	4	–	$\cos(\pi t / 4)$
23	14	8	1	2	30	–	$6t^2 - 1$	–
24	90	45	2	2	–	4	–	$2 \cos(\pi t / 2)$
25	96	48	1	2	–	5	–	$3 \sin(\pi t / 4)$
26	100	40	5	1	45	–	$4t^2 - 2$	–
27	41	22	5	2	30	–	$5 - t^2$	–
28	35	17	4	3	–	3	–	$\cos(\pi t / 6)$
29	10	5	2	2	–	2	–	$4 \cos(\pi t / 2)$
30	57	37	2	2	30	–	$5 - 3t^2$	–

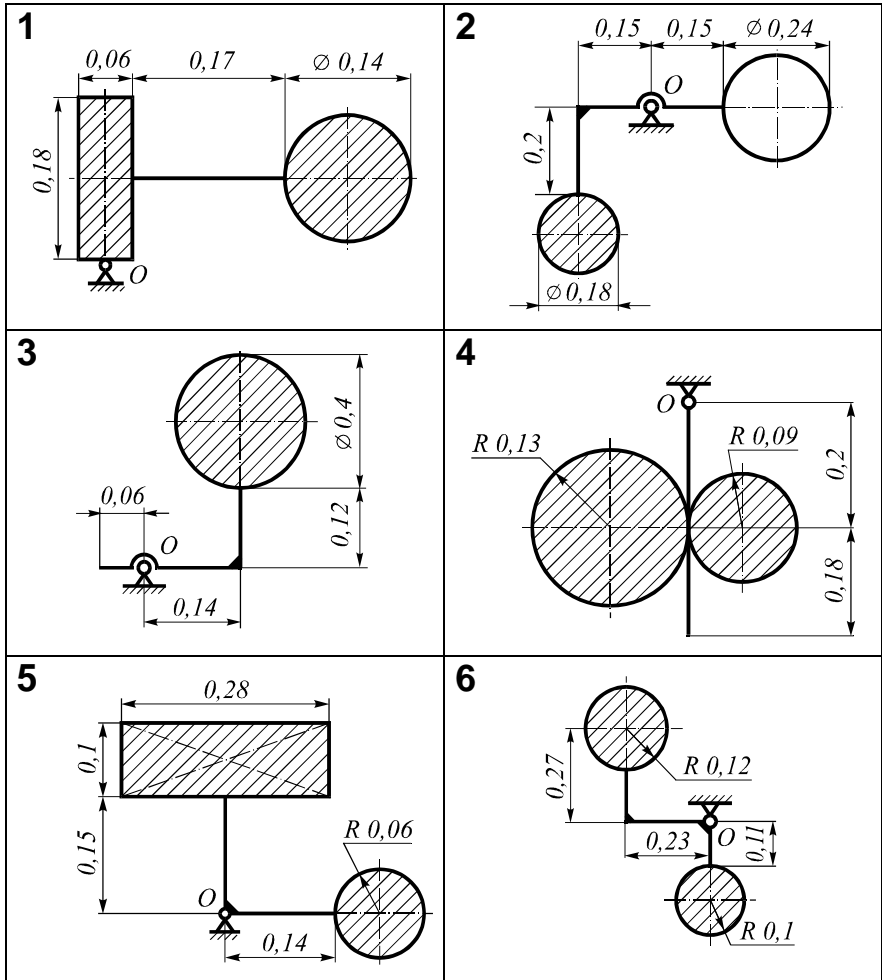

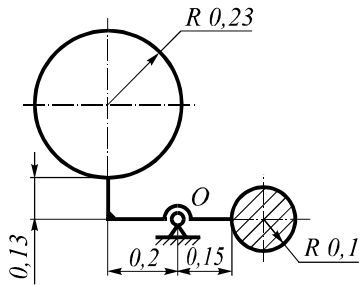
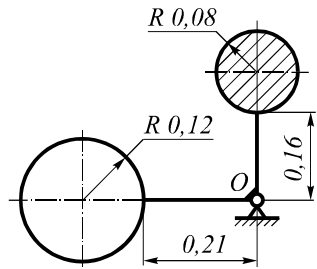
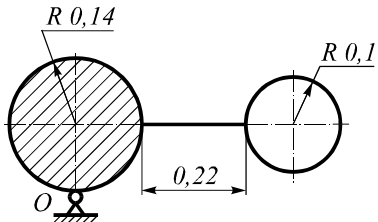
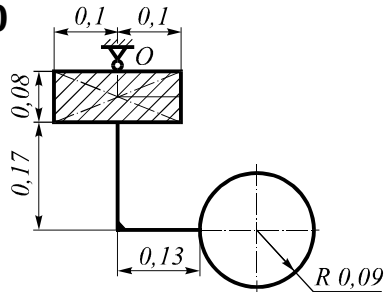
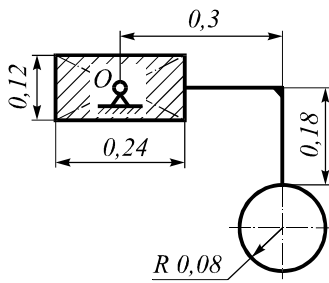
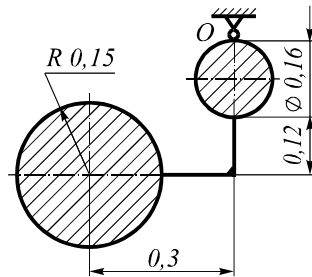
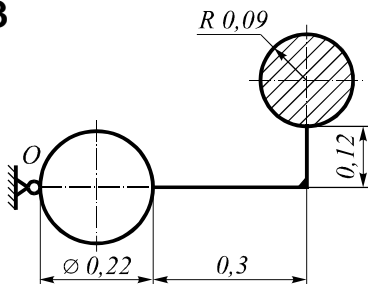
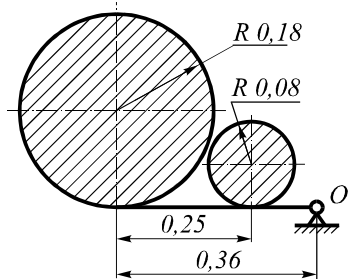
7**8****9****10****11****12****13****14**

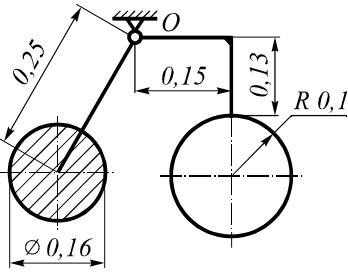
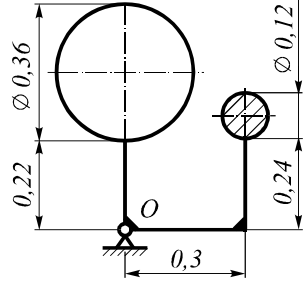
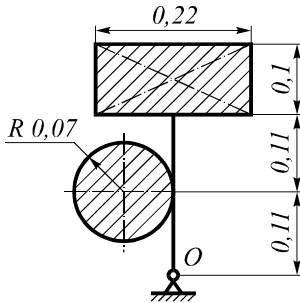
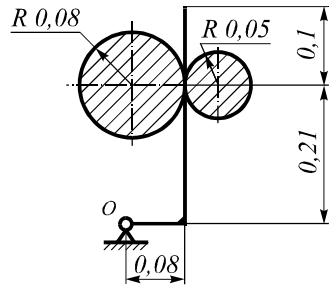
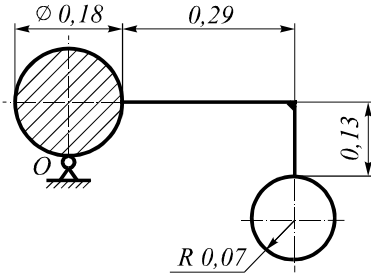
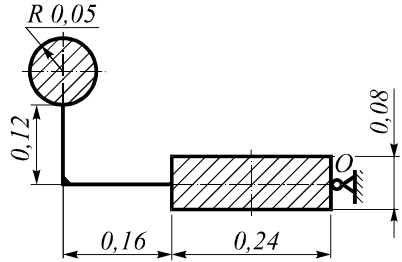
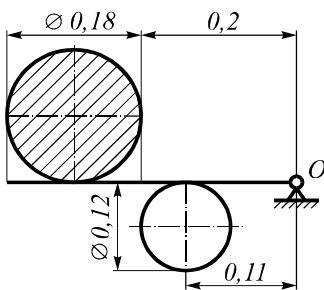
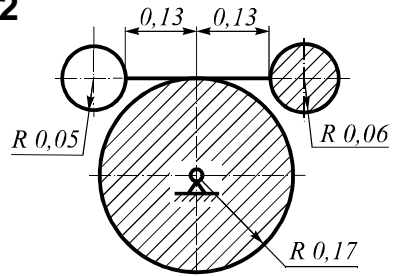
15**16****17****18****19****20****21****22**

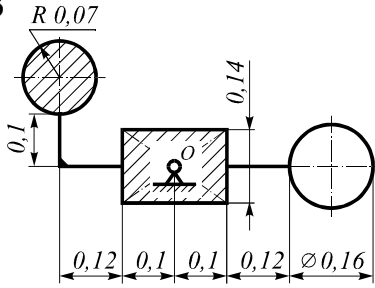
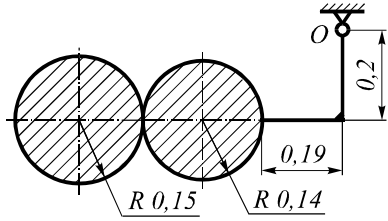
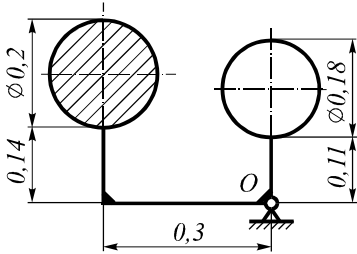
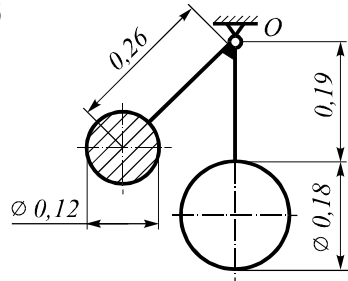
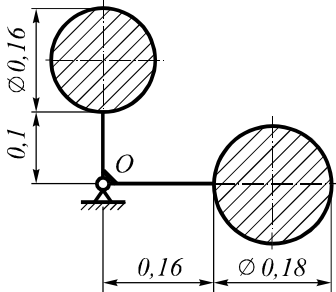
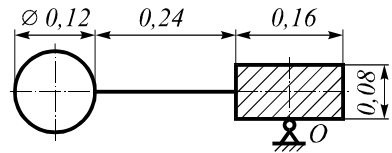
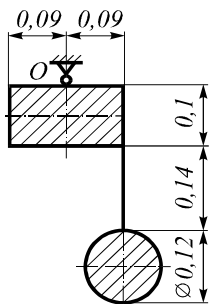
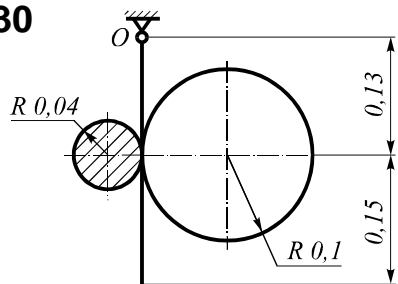
23**24****25****26****27****28****29****30**

4

1 m_1 ω_0 2 m_2

λ .

2.

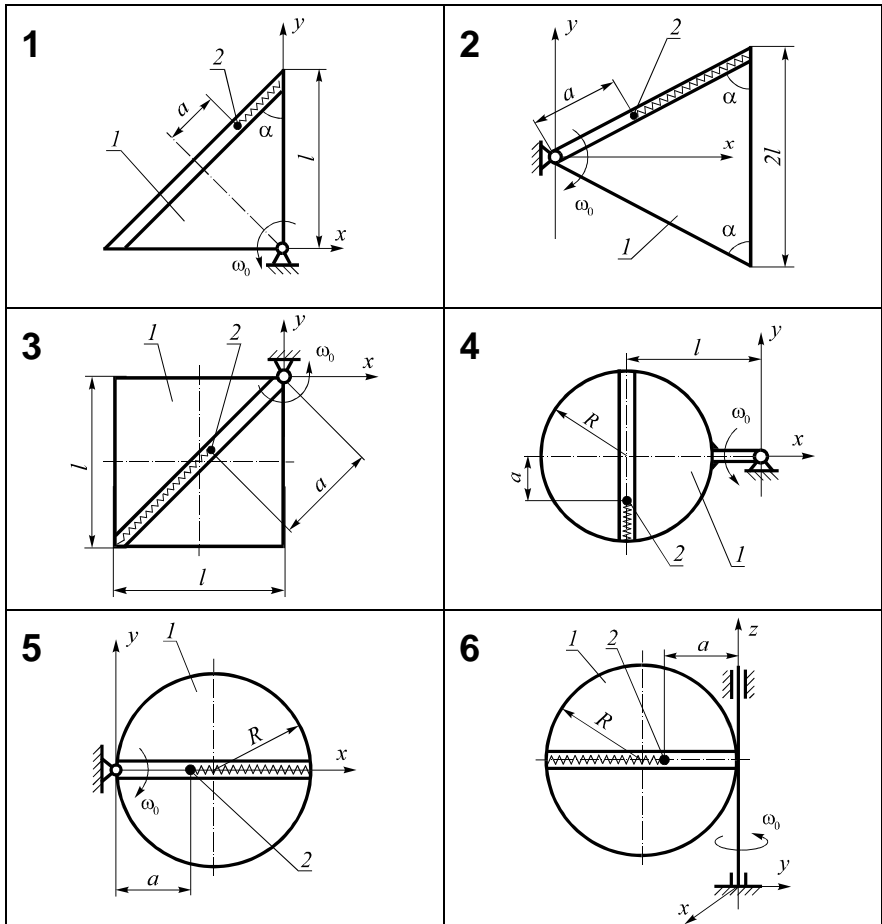

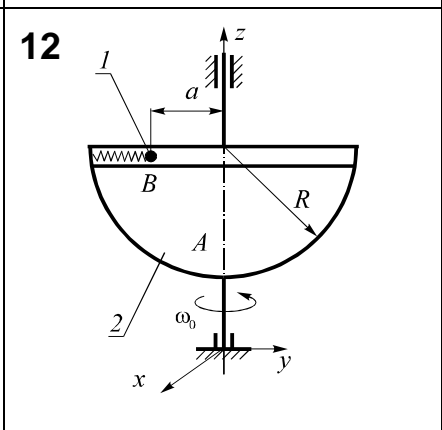
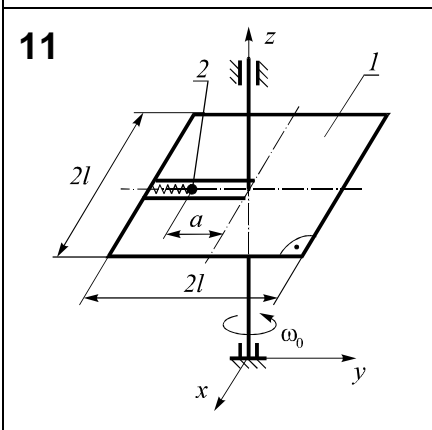
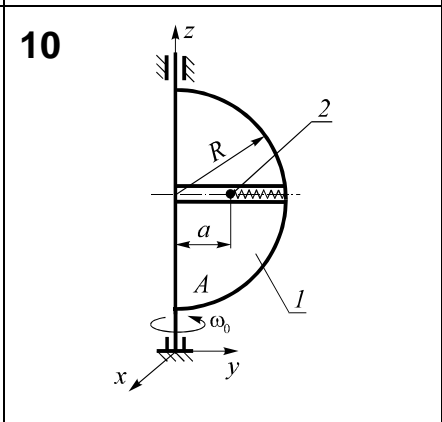
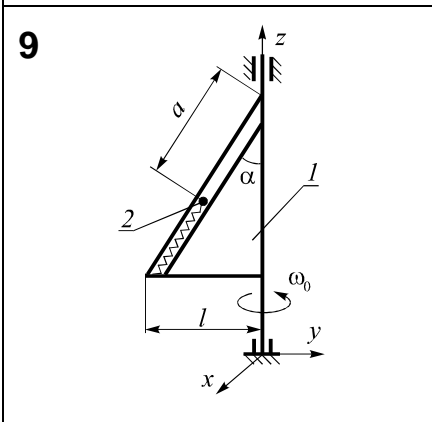
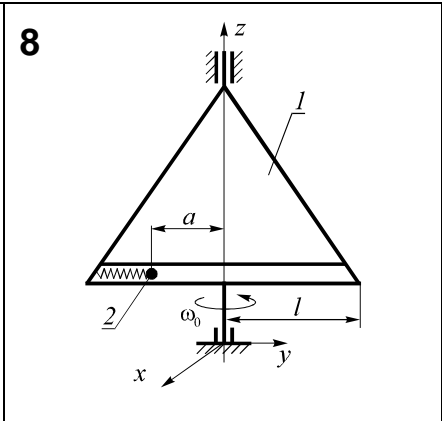
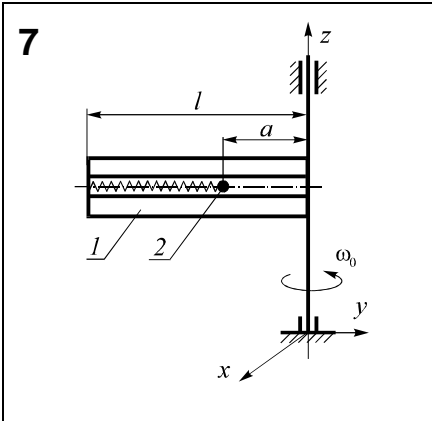

13

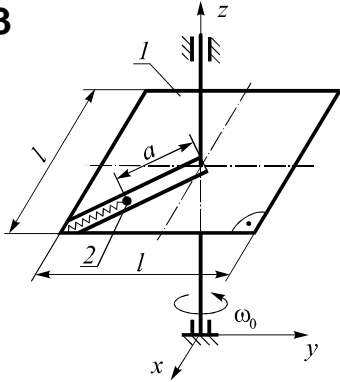

14

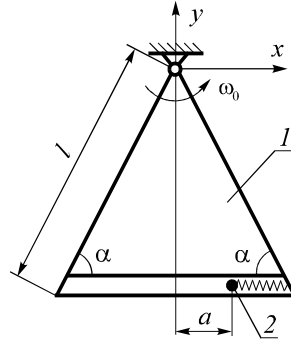

15

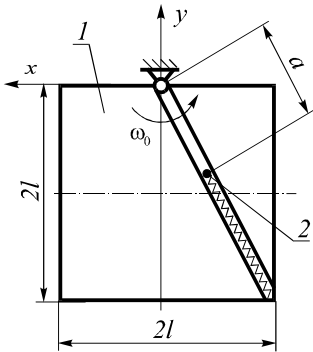

16

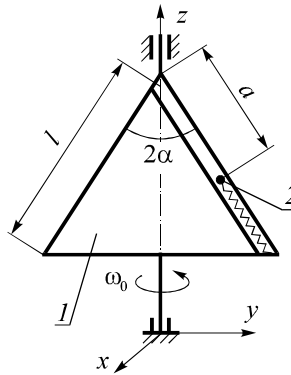

17

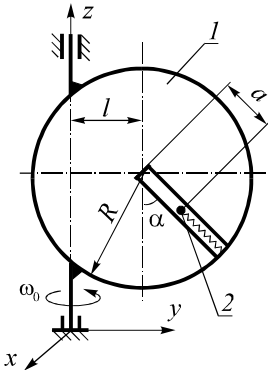

18

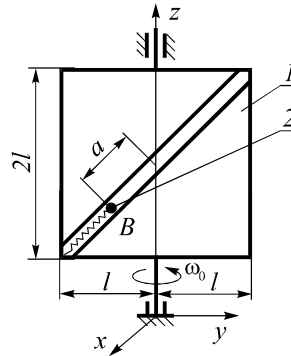

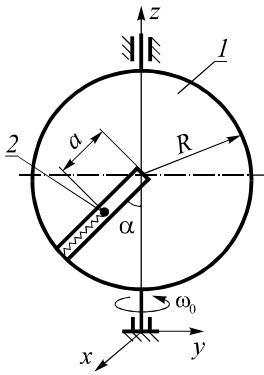
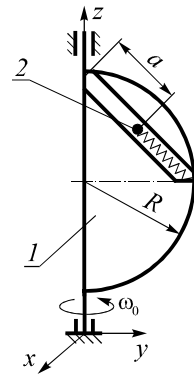
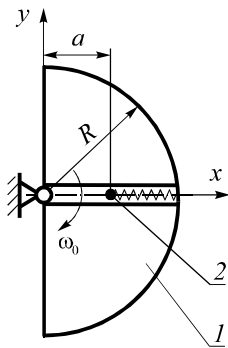
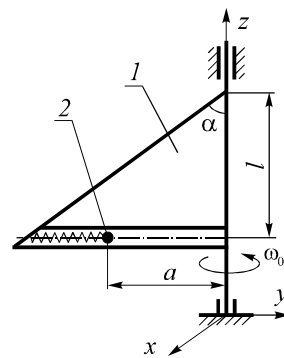
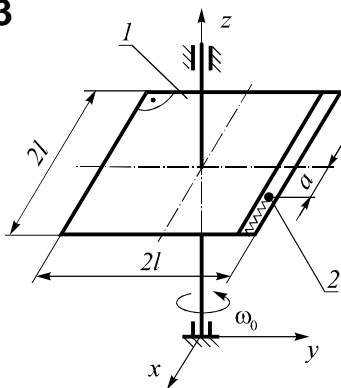
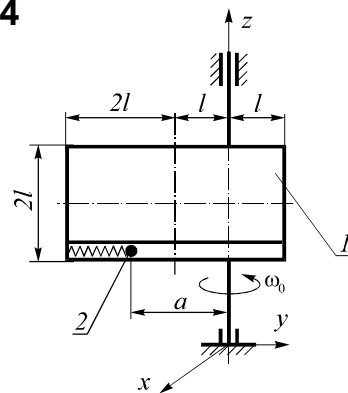
19**20****21****22****23****24**

25

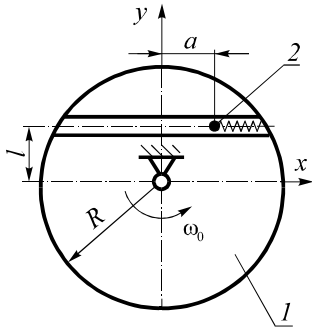

26

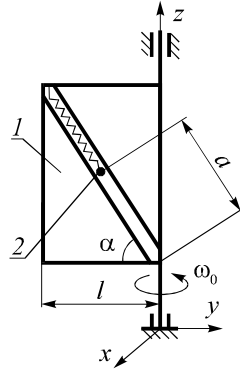

27

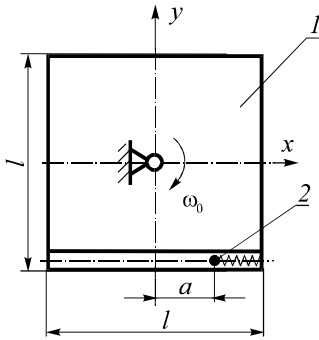

28

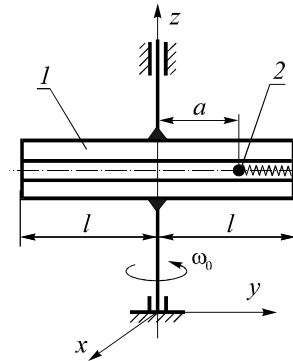

29

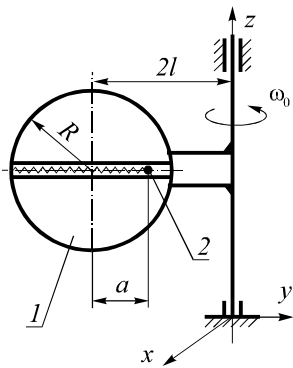

30

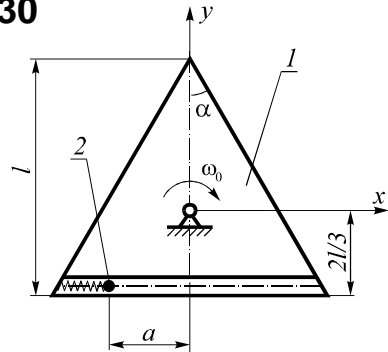

	m_1 ,	m_2 ,	ω_0 , c^{-1}	,	λ ,	R ,	l ,	α ,
1	30	0,5	10	1	0,5	–	4	45
2	40	1	5	2	0,3	–	4	60
3	20	1	2	1	0,2	–	3	–
4	6	0,8	10	1,5	0,5	3	4	–
5	4	0,5	6	3	1	4	–	–
6	6	1	10	1	0,1	3	–	–
7	2	0,2	5	2	0,5	–	4	–
8	10	0,8	8	3	0,4	–	6	–
9	4	0,5	20	0,5	0,3	–	2	30
10	30	3	6	0,4	0,1	1	–	–
11	20	2	10	1	0,5	–	3	–
12	6	0,4	4	3	0,2	5	–	–
13	6	2	10	0,5	0,5	–	4	–
14	8	0,5	50	2	0,5	–	5	60
15	2	0,2	6	1	0,4	–	2	–
16	12	2	15	3	0,5	–	6	30
17	8	0,4	20	0,5	0,3	2	0,5	45
18	50	0,5	20	2	0,3	–	5	–
19	20	1	12	0,7	0,3	2	–	30
20	5	0,1	30	2	0,4	4	–	–
21	10	0,5	8	0,4	0,1	1	–	–
22	16	0,2	4	1	0,2	–	2	60
23	4	0,1	20	0,8	0,2	–	3	–
24	20	1	5	2	0,5	–	2	–
25	12	2	15	0,8	0,2	5	1	–
26	10	1	100	1	1	–	3	60
27	40	2	40	0,7	0,3	–	2	–
28	10	1	20	3	0,4	–	6	–
29	5	0,2	10	1	0,5	2	3	–
30	20	0,5	50	1,8	0,2	–	3	30

5

m_1 m_2
 M , F , N
 f
 i_{2x}

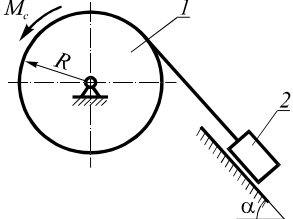
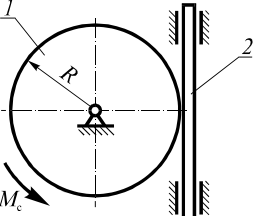
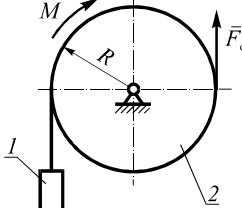
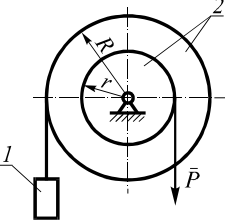
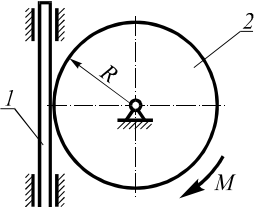
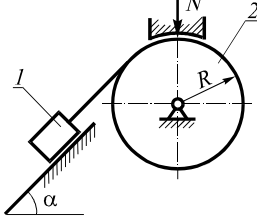
<p>1</p>  <p> $: m_1 = 3m; m_2 = 2m; \quad ; f; R; \alpha.$ $\epsilon_1.$ </p>	<p>2</p>  <p> $: m_1 = 2m; m_2 = 4m; \quad ; R.$ $a_2.$ </p>
<p>3</p>  <p> $: m_1 = 6m; m_2 = 3m; F; \quad ; R.$ $a_1.$ </p>	<p>4</p>  <p> $: m_1 = 3m; m_2 = 2m; \quad ; r; R; i_2.$ $a_1.$ </p>
<p>5</p>  <p> $: m_1 = m; m_2 = 2m; M; R.$ $a_1.$ </p>	<p>6</p>  <p> $: m_1 = m; m_2 = 3m; N; f; R; i_{2x}; \alpha.$ $\epsilon_2.$ </p>

7

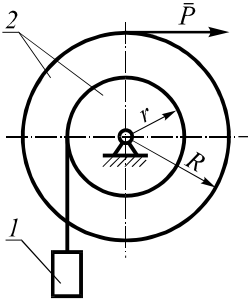

$: m_1 = m; m_2 = 3m; \quad ; r; R;$
 $i_2 = 2r.$

$\varepsilon_2.$

8

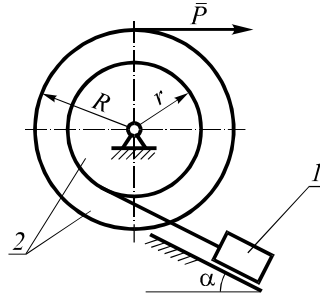

$: m_1 = 2m; m_2 = 3m; \quad ; \alpha; R; r;$
 $i_2 = r\sqrt{2}.$

$a_1.$

9

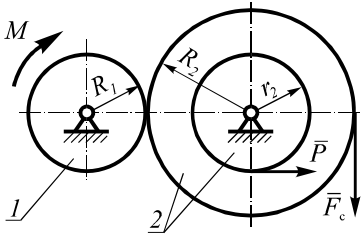

$: m_1 = 2m; m_2 = 3m; F; \quad ;$
 $R_1 = 1,5r; R_2 = 2r; r_2 = r; i_2 = r\sqrt{2}.$

$\varepsilon_2.$

10

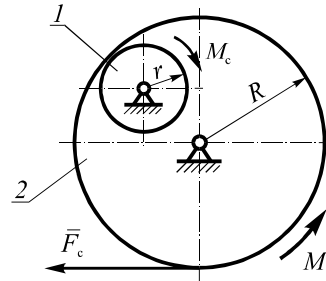

$: m_1 = m; m_2 = 4m; M; \quad ; F;$
 $R = 2r.$

$\varepsilon_1.$

11

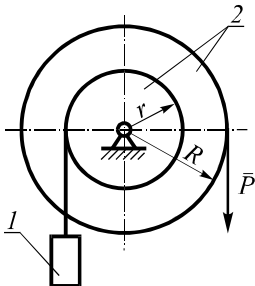

$: m_1 = 3m; m_2 = m; \quad ; R = 2r;$
 $i_2 = r\sqrt{5}.$

$\varepsilon_2.$

12

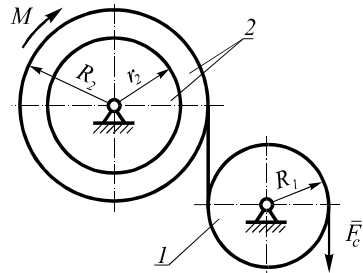

$: m_1 = m; m_2 = 2m; \quad ; F;$
 $R_2 = 2r; r_2 = r; R_1 = r; i_2 = r\sqrt{2}.$

$\varepsilon_2.$

13

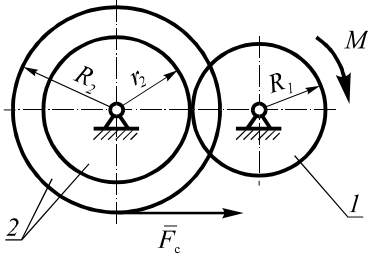

: $m_1 = 2m; m_2 = 5m; R_1 = 2r; F; r_2 = r; R_2 = 3r; i_2 = 2r.$

$\varepsilon_1.$

14

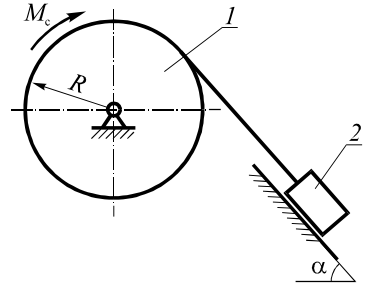

: $m_1 = 2m; m_2 = 4m; f; c; \alpha; R.$

$a_2.$

15

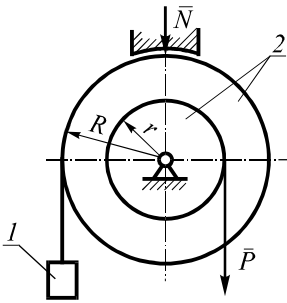

: $m_1 = 3m; m_2 = 2m; N; f; R = 3r; i_2 = r\sqrt{2}.$

$a_1.$

16

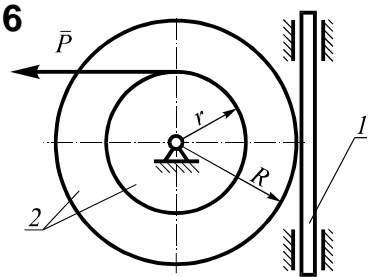

: $m_1 = 2m; m_2 = 3m; R; r; i_2 = r\sqrt{3}.$

$a_1.$

17

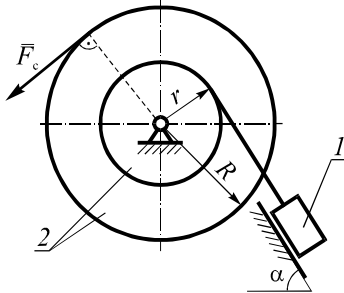

: $m_1 = 3m; m_2 = 2m; F; \alpha; R = 2r; i_2 = r\sqrt{2}.$

$\varepsilon_2.$

18

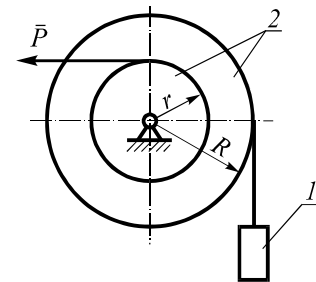

: $m_1 = 4m; m_2 = 3m; R = 2r; i_2 = r\sqrt{2}.$

$a_1.$

19

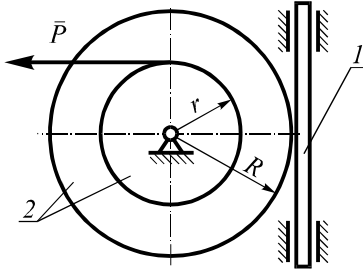

: $m_1 = m; m_2 = 2m$; ; $R; r$;
 $i_2 = r\sqrt{2}$.
 ε_2 .

20

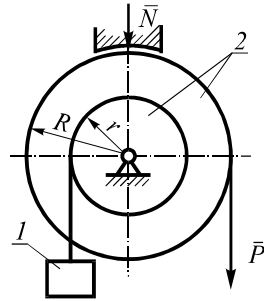

: $m_1 = 2m; m_2 = 3m$; ; $N; f$;
 $R = 2r; i_2 = r\sqrt{3}$.
 ε_2 .

21

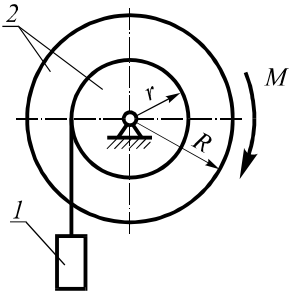

: $m_1 = 4m; m_2 = 3m$; ; $R; r$;
 $i_2 = 2r$.
 a_1 .

22

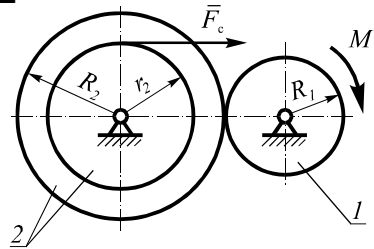

: $m_1 = m; m_2 = 3m$; ; $F; R_1 = r$;
 $R_2 = 2r; r_2 = r; i_2 = 2r$.
 ε_2 .

23

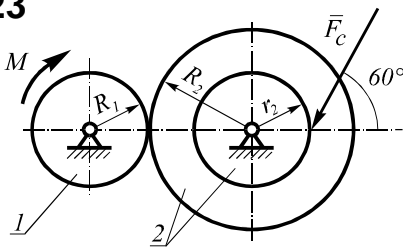

: $m_1 = 2m; m_2 = 6m$; ; F ;
 $R_1 = r_2 = r; R_2 = 3r; i_2 = r\sqrt{3}$.
 ε_1 .

24

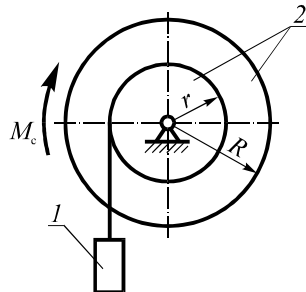

: $m_1 = m; m_2 = 2m$; ; $R = 2r$;
 $i_2 = r\sqrt{5}$.
 a_1 .

25

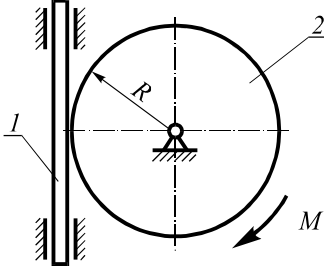

$: m_1 = m; m_2 = 3m; ; R.$

$\varepsilon_2.$

26

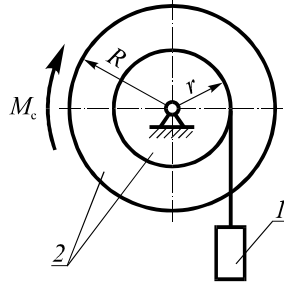

$: m_1 = 6m; m_2 = 4m; ; R = 3r;$

$i_2 = r\sqrt{3}.$

$\varepsilon_2.$

27

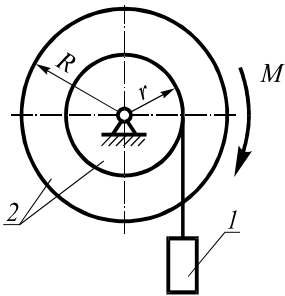

$: m_1 = 2m; m_2 = 3m; ; R = 2r;$

$i_2 = r\sqrt{5}.$

$\varepsilon_2.$

28

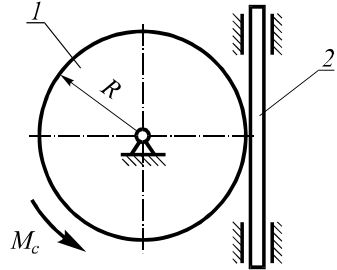

$: m_1 = 2m; m_2 = 5m; ; R.$

$\varepsilon_1.$

29

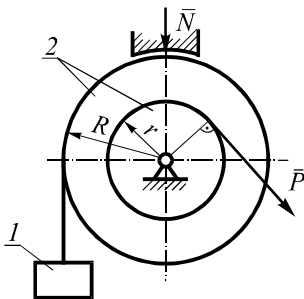

$: m_1 = 8m; m_2 = 5m; ; N; f;$

$R = 2r; i_2 = r\sqrt{2}.$

$a_1.$

30

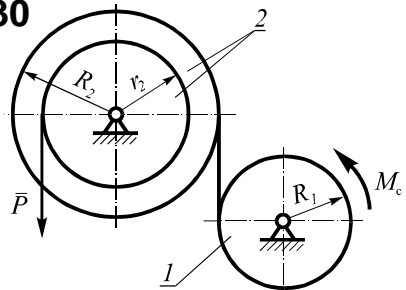

$: m_1 = m; m_2 = 3m; ; M;$

$R_2 = 3r; r_2 = r; R_1 = r; i_2 = r\sqrt{2}.$

$\varepsilon_1.$

6

i_z , R r m ,
 (f). δ -

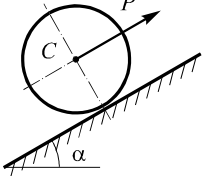
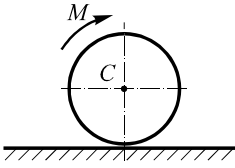
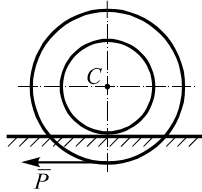
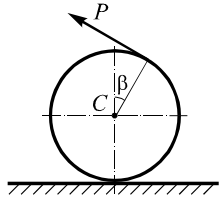
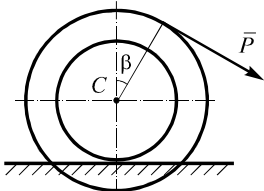
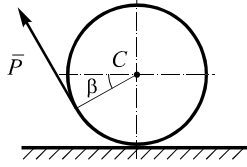
<p>1</p>  <p>: $m = 100$; $f = 0,2$; $\delta = 0,42$; $R = 0,2$. : , .</p>	<p>2</p>  <p>: $m = 120$; $f = 0,1$; $\delta = 0,6$; $R = 0,4$. : , .</p>
<p>3</p>  <p>: $m = 140$; $f = 0,4$; $R = 0,5$; $r = 0,2$; $i_{Cz} = 0,28$. : , .</p>	<p>4</p>  <p>: $m = 240$; $f = 0,3$; $\delta = 1$; $R = 0,5$; $= 30^\circ$. : , .</p>
<p>5</p>  <p>: $m = 180$; $f = 0,3$; $R = 0,5$; $r = 0,3$; $i_{Cz} = 0,5$; $= 30^\circ$. : , .</p>	<p>6</p>  <p>: $m = 240$; $R = 0,5$; $f = 0,3$; $\delta = 1,2$; $= 30^\circ$. : , .</p>

7

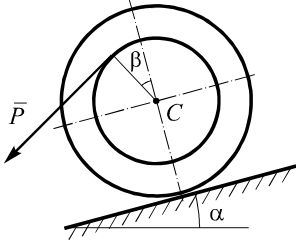

: $m = 190$; $f = 0,1$; $\delta = 0,8$;
 $R = 0,6$; $r = 0,2$; $i_{Cz} = 0,28$;
 $= 15^\circ$; $= 30^\circ$.
 : , .

8

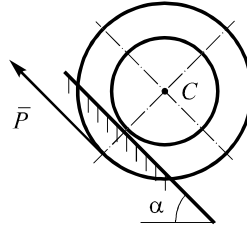

: $m = 240$; $f = 0,3$; $R = 0,8$;
 $r = 0,4$; $i_{Cz} = 1,26$; $\alpha = 45^\circ$.
 : , .

9

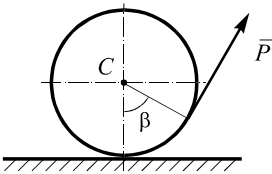

: $m = 145$; $f = 0,18$; $\delta = 1$;
 $R = 0,3$; $\beta = 60^\circ$.
 : , .

10

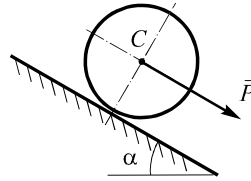

: $m = 210$; $f = 0,1$; $R = 0,4$;
 $\delta = 0,8$; $= 30^\circ$.
 : , .

11

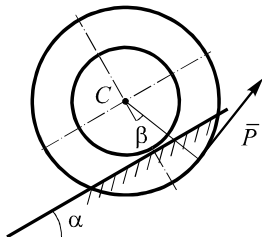

: $m = 220$; $f = 0,32$; $R = 0,6$;
 $r = 0,3$; $i_{Cz} = 0,64$; $= 30^\circ$;
 $= 20^\circ$.
 : , .

12

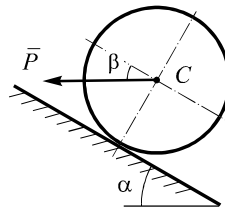

: $m = 120$; $f = 0,1$; $\delta = 0,9$;
 $R = 0,4$.
 : , .

13

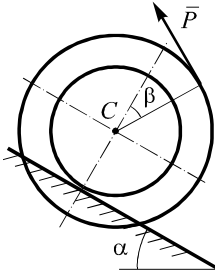

: $m = 110$; $f = 0,25$; $R = 0,5$;
 $r = 0,3$; $i_{Cz} = 0,6$; $\delta = 30^\circ$;
 $\alpha = 15^\circ$.

: , .

14

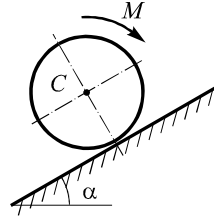

: $m = 300$; $R = 0,5$; $f = 0,4$;
 $\delta = 0,86$; $\alpha = 30^\circ$.

: , .

15

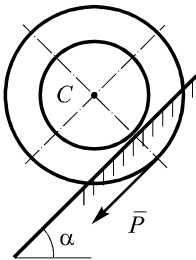

: $m = 120$; $f = 0,2$; $R = 0,4$;
 $r = 0,2$; $i_{Cz} = 0,28$.

: , .

16

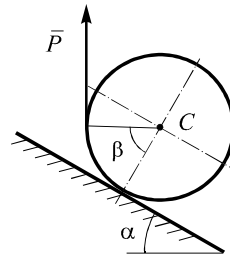

: $m = 170$; $f = 0,5$; $\delta = 0,7$;
 $R = 0,4$; $\alpha = 30^\circ$; $\beta = 60$.

: , .

17

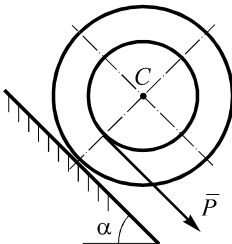

: $m = 220$; $f = 0,5$; $\delta = 0,6$;
 $R = 0,8$; $r = 0,2$; $i_{Cz} = 0,28$;
 $\alpha = 45^\circ$.

: , .

18

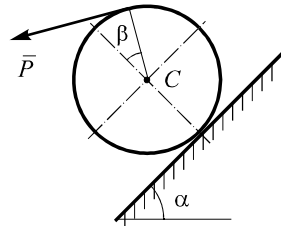

: $m = 150$; $R = 0,6$; $f = 0,25$;
 $\delta = 0,92$; $\alpha = 15^\circ$; $\beta = 30^\circ$.

: , .

19

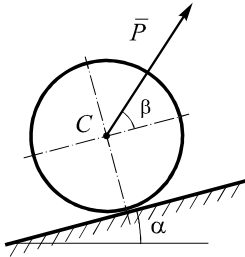

: $m = 140$; $f = 0,22$; $\delta = 1$;
 $R = 0,6$; $\alpha = 15^\circ$; $\beta = 45$.
 ; , .

20

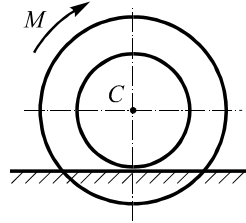

: $m = 200$; $f = 0,3$; $R = 0,8$;
 $r = 0,4$; $i_{Cz} = 0,7$.
 ; , .

21

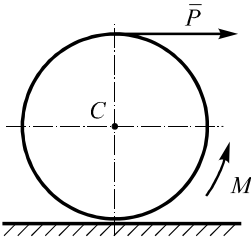

: $m = 140$; $f = 0,12$; $R = 0,3$;
 $\delta = 0,9$.
 ; , .

22

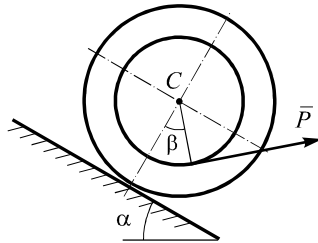

: $m = 290$; $f = 0,5$; $R = 0,6$;
 $r = 0,4$; $i_{Cz} = 0,56$.
 ; ; .

23

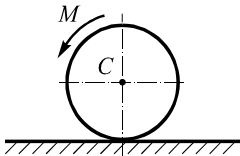

: $m = 100$; $R = 0,6$; $f = 0,2$;
 $\delta = 0,8$.
 ; , .

24

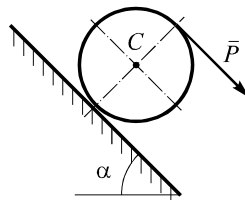

: $m = 120$; $R = 0,5$; $f = 0,4$;
 $\delta = 0,9$.
 ; , .

25

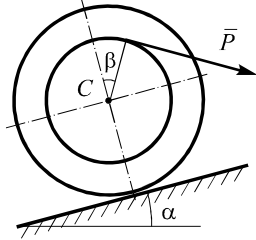

: $m = 200$; $f = 0,3$; $i_{Cz} = 0,42$
 $R = 0,4$; $r = 0,3$; $\delta = 15^\circ$;
 $\delta = 30^\circ$.
 : , .

26

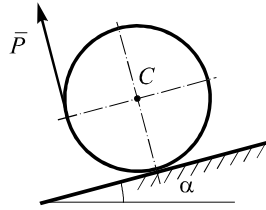

: $m = 225$; $f = 0,1$; $R = 0,8$;
 $\delta = 1,2$; $\delta = 45^\circ$.
 : , .

27

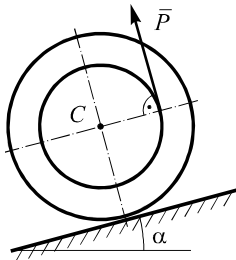

: $m = 160$; $f = 0,4$; $R = 0,4$;
 $r = 0,2$; $i_{Cz} = 0,28$; $\delta = 30^\circ$.
 : ; .

28

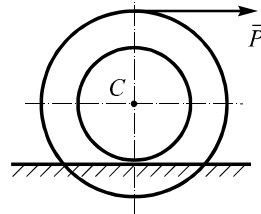

: $m = 140$; $f = 0,2$; $R = 0,5$;
 $r = 0,3$; $i_{Cz} = 0,42$; $\delta = 0,6$.
 : , .

29

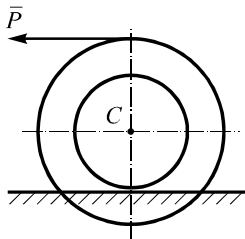

: $m = 100$; $f = 0,12$; $R = 0,8$;
 $r = 0,5$; $i_{Cz} = 1$; $\delta = 0,8$.
 : , .

30

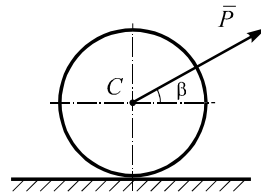

: $m = 230$; $f = 0,2$; $\delta = 1,2$;
 $R = 0,8$; $\delta = 30^\circ$.
 : , .

v_A , ω_1, ω_2 , m_i ,
 « » , « » ,
 « » , « » »

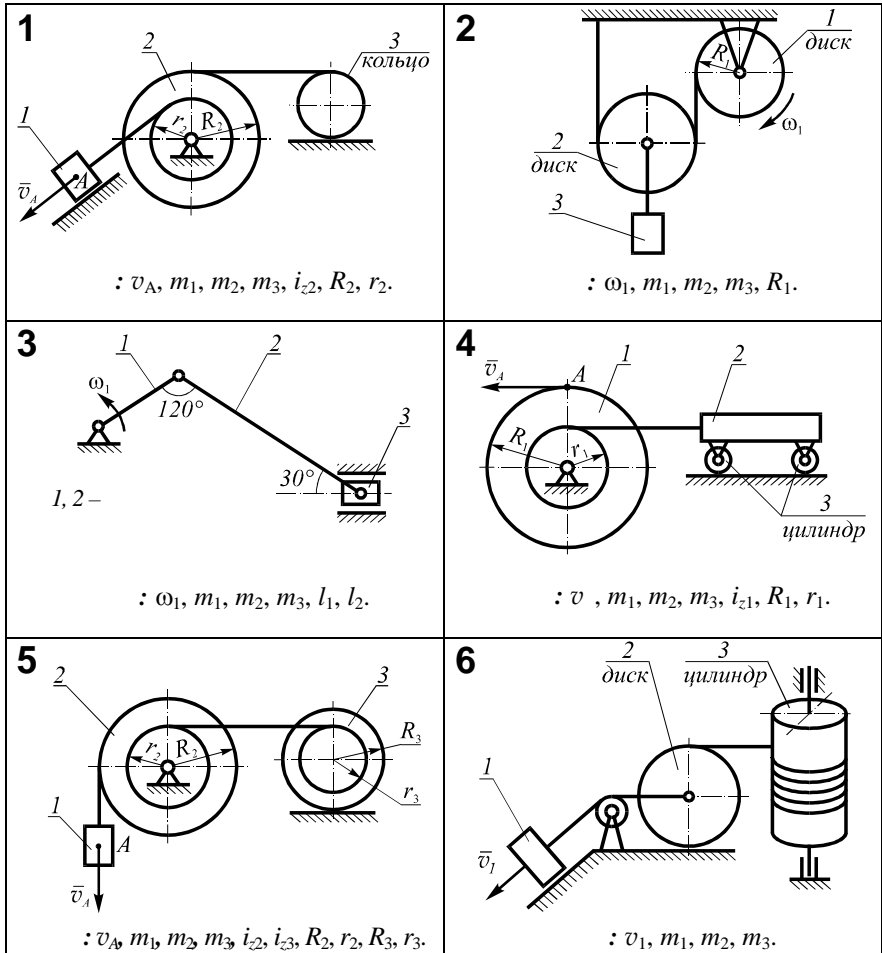

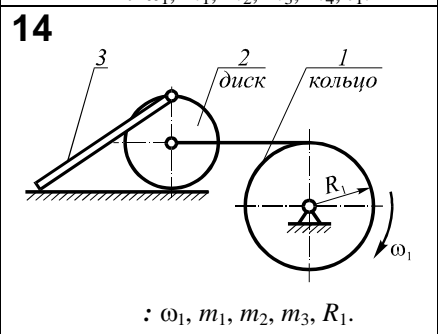
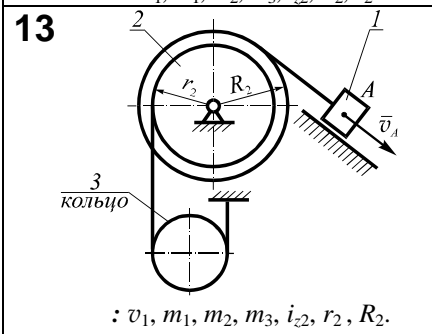
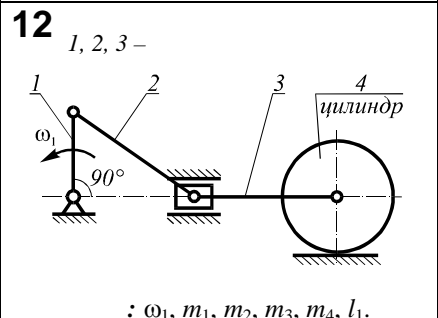
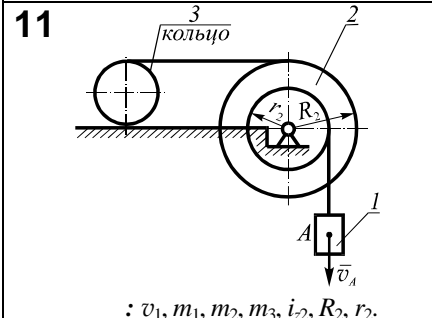
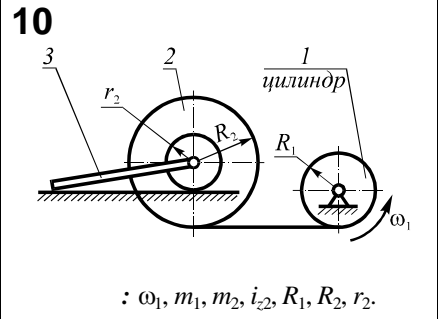
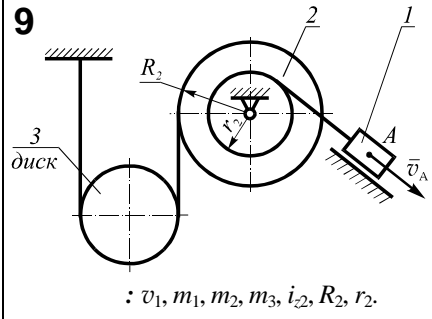
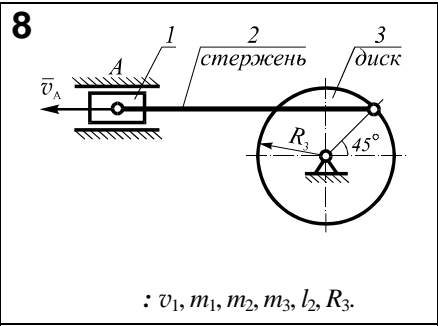
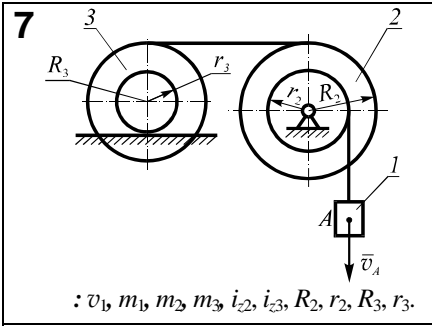

15

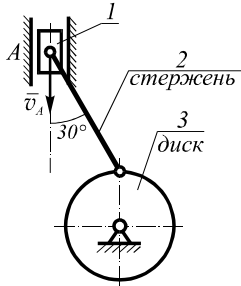

: $v_1, m_1, m_2, m_3, R_3.$

16

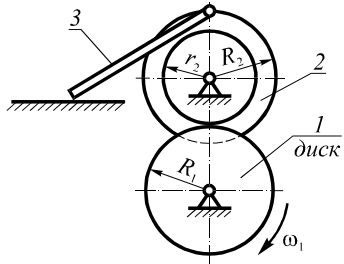

: $\omega_1, m_1, m_2, m_3, i_{z2}, R_1, R_2, r_2.$

17

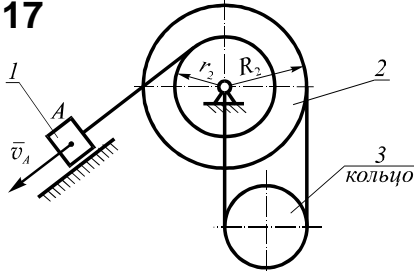

: $v_A, m_1, m_2, m_3, i_{z2}, R_2, r_2.$

18

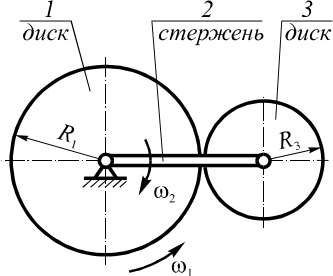

: $1, 2, m_1, m_2, m_3, R_1, R_3.$

19

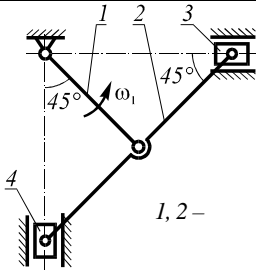

: $\omega_1, m_1, m_2, m_3, m_4, l_1.$

20

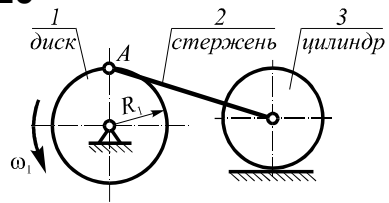

: $\omega_1, m_1, m_2, m_3, R_1.$

21

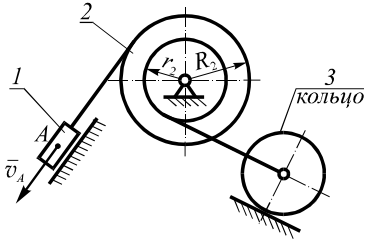

: $v_1, m_1, m_2, m_3, i_{z2}, R_2, r_2.$

22

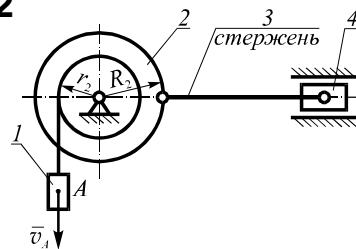

: $v_1, m_1, m_2, m_3, m_4, i_{z2}, R_2, r_2.$

23

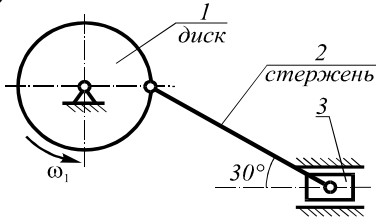

: $\omega_1, m_1, m_2, m_3, R_1$.

24

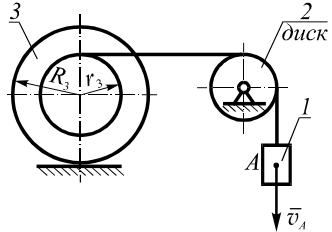

: $v_1, m_1, m_2, m_3, i_{23}, R_3, r_3$.

25

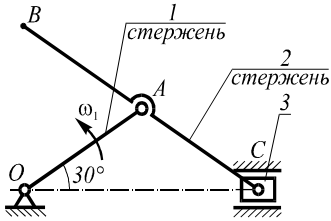

: $\omega_1, m_1, m_2, m_3, AB = AC = l_1$.

26

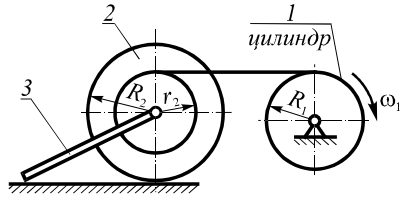

: $\omega_1, m_1, m_2, m_3, i_{23}, R_1, R_2, r_2$.

27

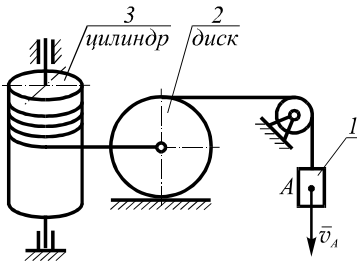

: v_1, m_1, m_2, m_3 .

28

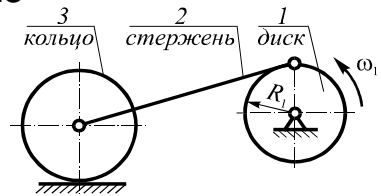

: $\omega_1, m_1, m_2, m_3, R_1$.

29

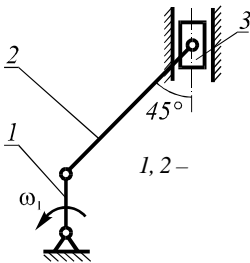

: $\omega_1, m_1, m_2, m_3, l_1, l_2$.

30

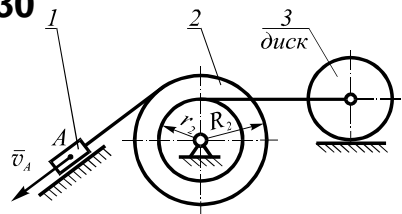

: $v_A, m_1, m_2, m_3, i_{23}, R_2, r_2$.

8

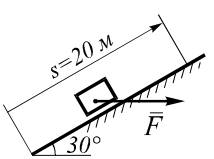
<p>1</p> <p>$s = at^3$, -</p> <p>$R = \mu v^2$, μ -</p> <p>, v -</p> <p style="text-align: right;">$s?$</p>	<p>2</p> <p>, $= 30^\circ$</p> <p>$m = 20$,</p> <p>$f = 0,05$.</p> <p>$s = 1000$?</p>
<p>3</p> <p>0,6 .</p> <p>$v_1 = 2000$,</p> <p>- $v_2 = 1200$.</p> <p>, 10</p> <p>, 120 .</p>	<p>4</p>  <p>$s = 20 \text{ M}$</p> <p>30°</p> <p>, 20</p> <p>, 30°.</p> <p>0,2.</p>
<p>5</p> <p>, 9000 ,</p> <p>15 / .</p> <p>, ,</p> <p>« -</p> <p>» 60 % ,</p> <p>3 / .</p>	<p>6</p> <p>, 0,2 ,</p> <p>, 30°.</p> <p>5 .</p> <p>0,01 .</p>

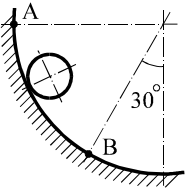
<p>7 $m = 5$</p> <p>$F = 12t^2,$ $x = t^4.$</p> <p>$x_1 = 1$ $x_2 = 4$</p>	<p>8 $m = 1000$</p> <p>$i = \text{tg} = 0,009$ ()</p> <p>36 / .</p> <p>1 .</p> <p>100</p>
<p>9 $m = 5$</p> <p>$c_2 = 200$ / ,</p> <p>$c_1 = 120$ /</p> <p>20 .</p>	<p>10 10</p> <p>1</p>  <p>5 .</p>
<p>11 ,</p> <p>30°,</p> <p>10</p> <p>100 .</p> <p>0,05 .</p>	<p>12</p> <p>60 /</p> <p>900</p> <p>= 0,8.</p>
<p>13</p> <p>90 ³ 10 .</p> <p>= 0,7.</p>	<p>14</p> <p>2 ,</p> <p>?</p>

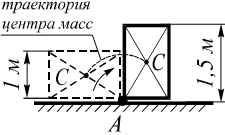
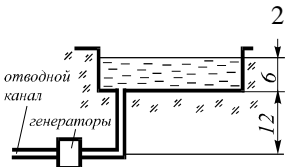
<p>15</p> <p>800</p> <p>$= 0,8?$</p> <p>200 10</p>	<p>16</p> <p>$h = 6$</p> <p>80 %</p> <p>600 $^3/$</p>
<p>17</p> <p>40</p> <p>2000 . . (1 . . 736),</p> <p>30°.</p> <p>?</p>	<p>18</p> <p>$c = 50 /$,</p> <p>3 .</p>
<p>19</p>  <p>траектория центра масс</p> <p>1 м</p> <p>1,5 м</p> <p>А</p> <p>80</p>	<p>20</p>  <p>отводной канал</p> <p>генераторы</p> <p>2</p> <p>6</p> <p>12</p> <p>6</p> <p>12</p>
<p>21</p> <p>$m = 10$</p> <p>$= 30^\circ$</p> <p>$h = 5$</p> <p>$f = 0,25$.</p>	<p>22</p> <p>18 / .</p> <p>90</p> <p>75 ?</p>

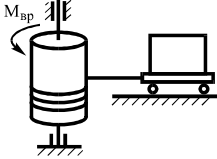
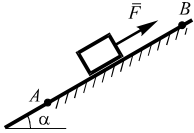
<p>23</p>  <p>0,05</p> <p>$n = 750$ /</p> <p>$d = 0,5$</p>	<p>24 $m = 5$</p>  <p>$\alpha = 30^\circ$</p> <p>$F = 9x^2$ ().</p> <p>$f = 0,2$.</p> <p>$x_1 = 2$</p> <p>$x_2 = 6$</p>
<p>25</p> <p>50</p> <p>500</p> <p>30</p>	<p>26</p> <p>$R = 0,2$</p> <p>$F = 100$</p> <p>$f = 0,25$.</p> <p>15</p>
<p>27</p> <p>6</p> <p>120</p> <p>5</p>	<p>28</p> <p>4</p> <p>75</p>
<p>29</p> <p>$p = 40$ / 2,</p> <p>$N = 50$</p> <p>80 %.</p>	<p>30</p> <p>10</p> <p>20</p> <p>30 ?</p> <p>0,5</p> <p>-5</p>

$m.$

$f,$

$-\alpha.$

1

s.

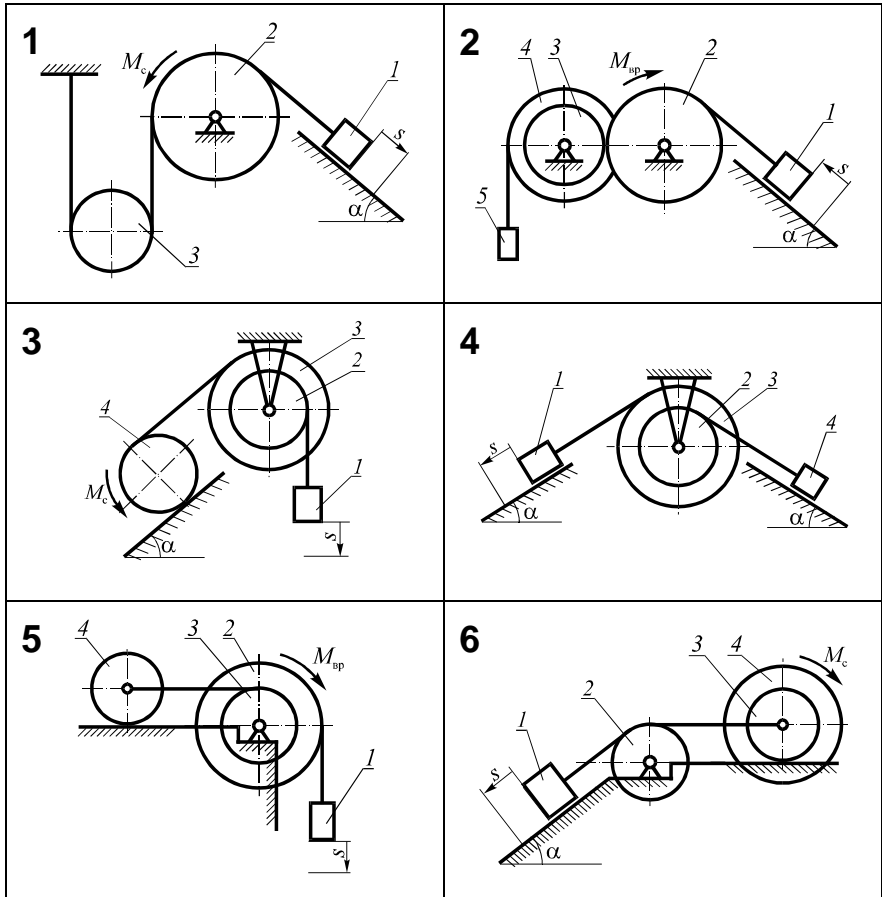

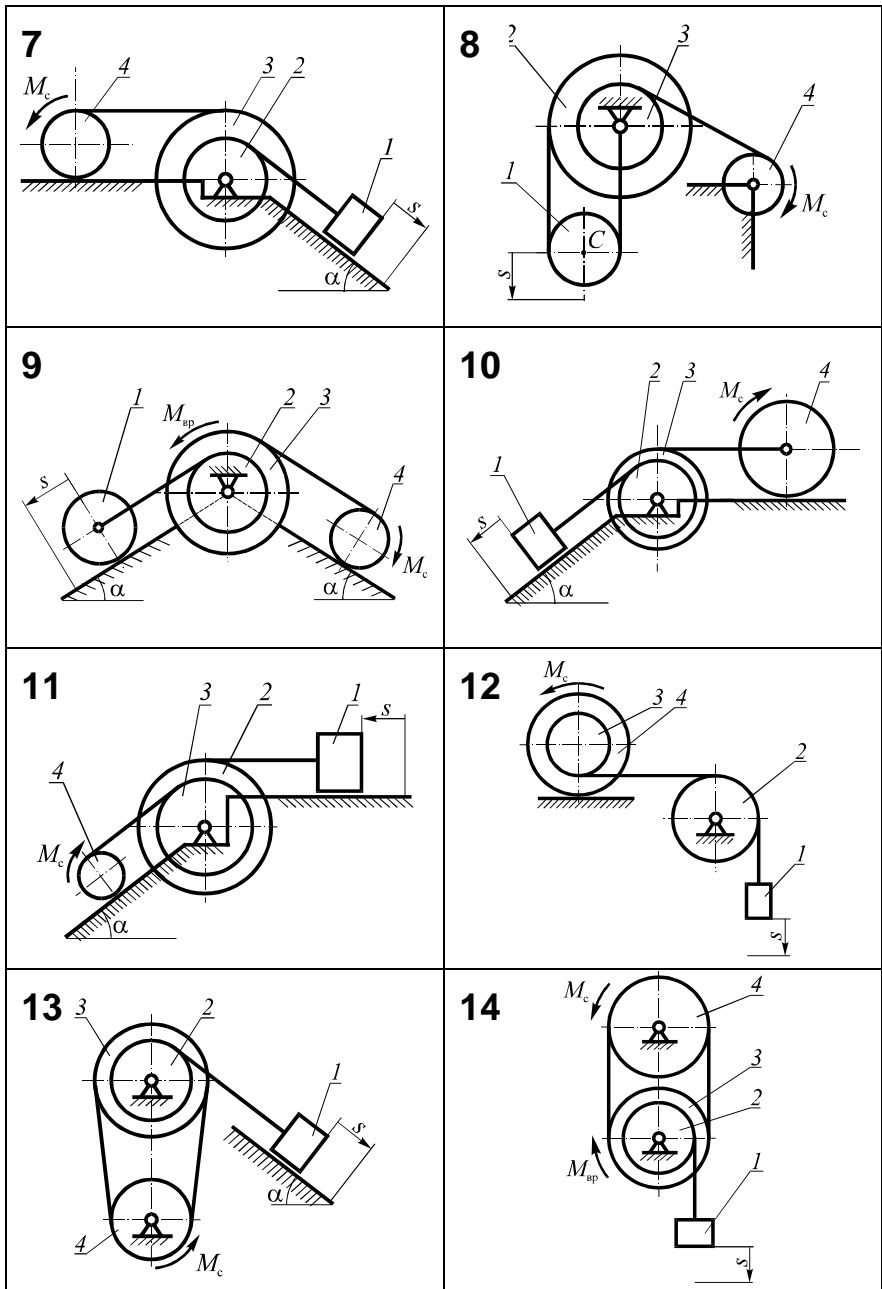

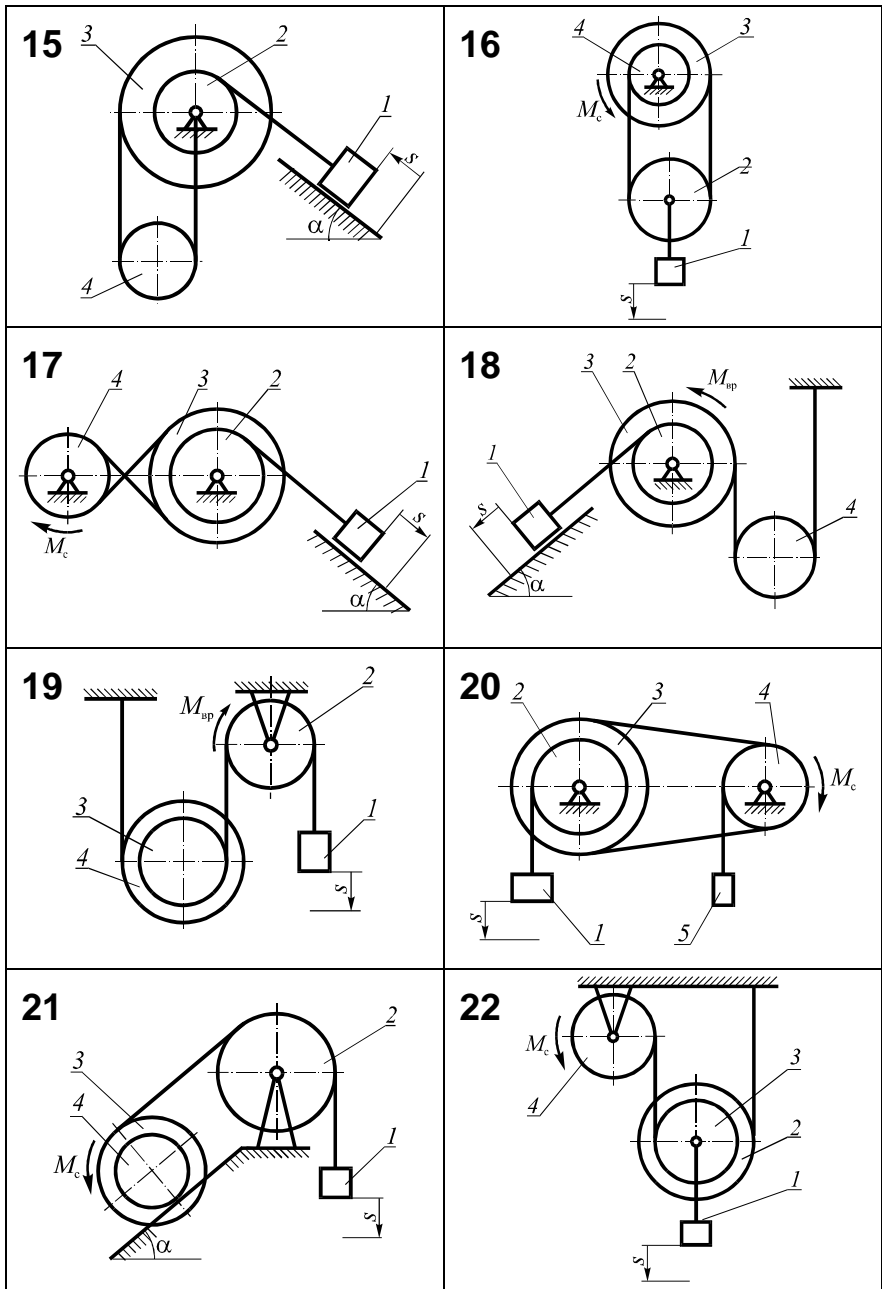

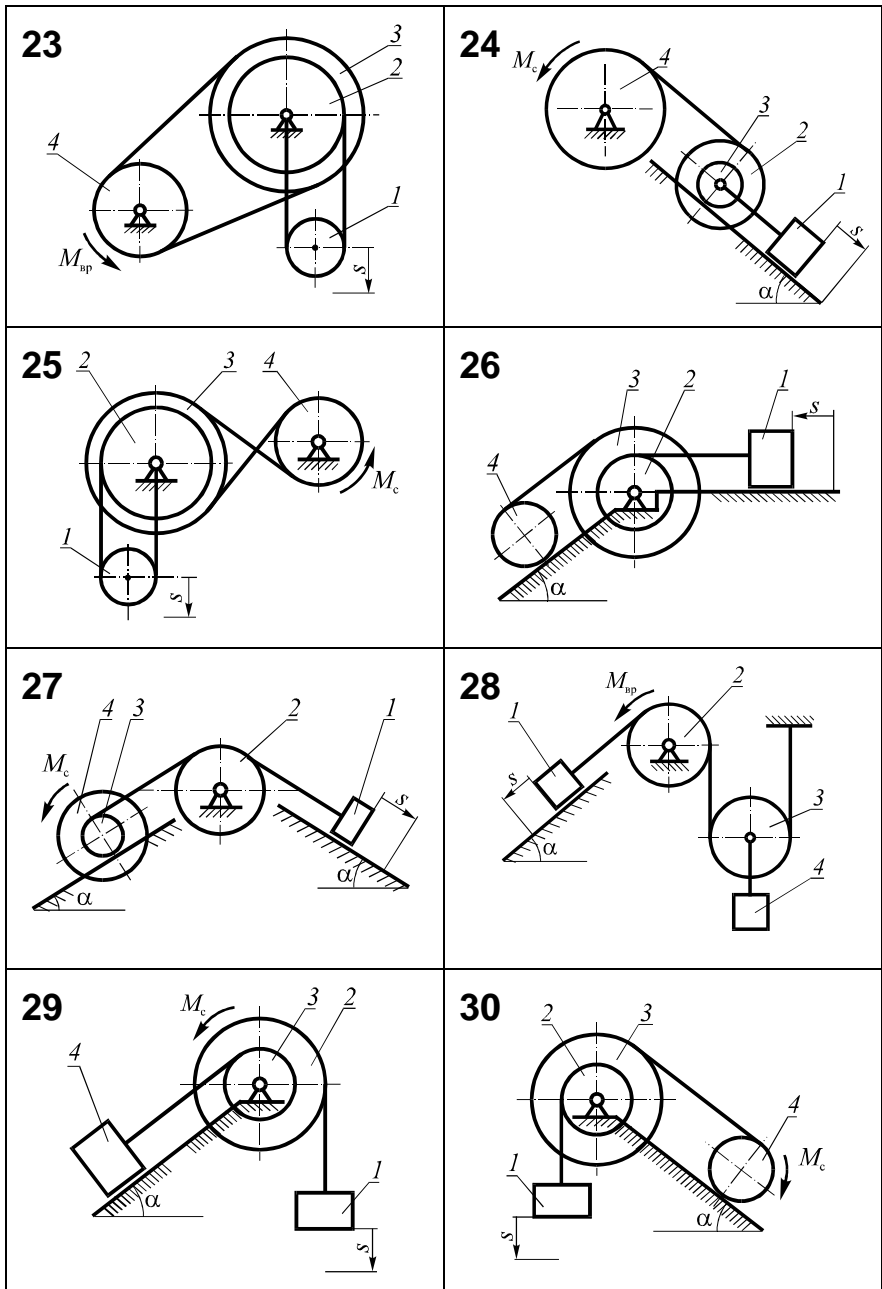

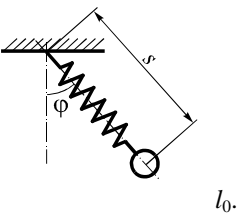
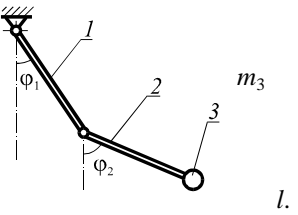
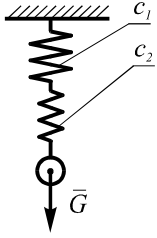

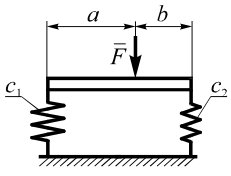
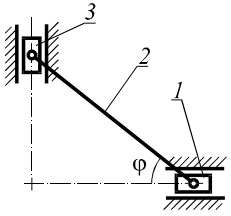
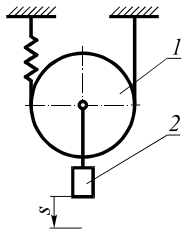
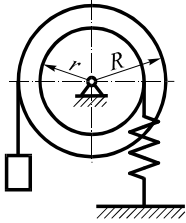
<p>1 $m,$</p>  <p style="text-align: right;">$l_0.$</p> <p style="text-align: center;">s</p>	<p>2</p>  <p style="text-align: right;">$l.$</p> <p style="text-align: center;">$1, 2.$</p>
<p>3 l</p> <p style="text-align: center;">$c.$</p> <p>$\varphi = \varphi_0 \sin kt .$</p>	<p>4</p> <p style="text-align: right;">$F = \frac{k}{r},$</p> <p style="text-align: right;">$; r -$</p> <p style="text-align: right;">R</p> <p style="text-align: center;">$(\quad) r.$</p> <p style="text-align: center;">$r.$</p>
<p>5 $m,$</p>	<p>6</p>  <p style="text-align: center;">$c_1 \quad c_2.$</p> <p style="text-align: center;">?</p>

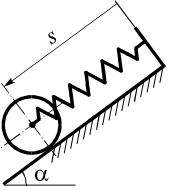
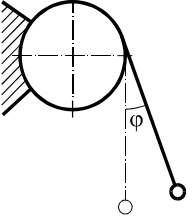
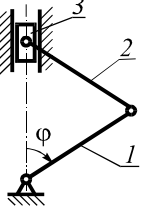
<p>7</p>  <p>c_1 c_2, F.</p> <p>$c_1 / c_2 = a / b$.</p>	<p>8</p> <p>m, v_0</p> <p>h.</p>
<p>9</p>  <p>1 3, 2 2 l φ m.</p>	<p>10</p>  <p>1 m_1 l_2, l c. 2 m_2. s.</p>
<p>11</p>  <p>m, R r. c.</p>	<p>12</p> <p>m, 0</p> <p>m, R (r).</p>
<p>13</p> <p>m, v_0.</p> <p>$2/3$</p>	<p>14</p> <p>m, v_0</p> <p>α</p>

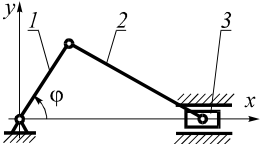
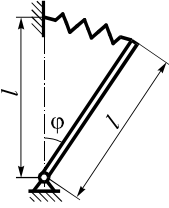
<p>15</p>  <p>s</p> <p>α</p> <p>$m,$</p> <p>$c,$</p> <p>$s.$</p> <p>$a.$</p>	<p>16</p>  <p>$m,$</p> <p>$r.$</p> <p>ϕ</p> <p>$l.$</p>
<p>17</p> <p>v_0</p> <p>α</p> <p>$m,$</p>	<p>18</p> <p>$m,$</p> <p>$v_0.$</p>
<p>19</p> <p>v</p> <p>m</p> <p>$h.$</p>	<p>20</p> <p>$l.$</p> <p>α</p> <p>$m,$</p>
<p>21</p>  <p>$l_1 = l_2 = l.$</p> <p>$m_1, m_2, m_3.$</p> <p>ϕ</p> <p>c</p>	<p>22</p> <p>l</p> <p>m</p>

<p>23 , m,</p> <p>l,</p> <p>ω -</p>	<p>24 , m,</p> <p>$v_0?$</p>
<p>25 , m,</p> <p>$x = v_0 t \cos \alpha_0$,</p> <p>$y = v_0 t \sin \alpha_0 - \frac{gt^2}{2}$.</p>	<p>26 , m,</p> <p>l,</p> <p>α,</p> <p>ω,</p> <p>b</p>
<p>27</p>  <p>l_1, l_2 , m_1, m_2,</p> <p>m_3.</p>	<p>28 m l -</p>  <p>c.</p> <p>a.</p>
<p>29 , m,</p> <p>v_0,</p> <p>h</p>	<p>30 , m,</p> <p>r</p>

<p>1</p> <p>$m = m_0 + \mu t.$</p> <p>$u = u_0 e^{-\beta t},$ $m_0, u_0,$</p> <p>, -</p>	<p>2</p> <p>$f.$</p> <p>$m = m_0 - \mu t .$</p> <p>,</p> <p>$u.$</p> <p>$v_0.$</p>
<p>3</p> <p>$- m_0.$</p> <p>$- u.$</p> <p>,</p>	<p>4</p> <p>,</p> <p>,</p> <p>$u = \text{const},$</p> <p>$m_0?$</p>

<p>5</p>  <p>n</p> <p>$v.$</p> <p>$m.$</p> <p>$r.$</p>	<p>6</p> <p>$m = m_0 - \mu t .$</p> <p>$u = \text{const.}$</p> <p>$m_0/2.$</p> <p>$l,$</p> <p>$v_0.$</p>
<p>7</p>	<p>8</p> <p>$m = m_0 - \mu t.$</p> <p>$u.$</p> <p>$m_0/2?$</p>

<p>9</p> <p>.....</p> <p>$v.$</p> <p>μ . C</p> <p>.....</p> <p>$f.$</p> <p>.....</p>	<p>10</p> <p>.....</p> <p>.....</p> <p>.....</p> <p>.....</p> <p>$l.$</p>
<p>11</p> <p>.....</p> <p>.....</p> <p>.....</p> <p>$a = a_0 e^{-\alpha t}$,</p> <p>$m_0.$</p> <p>$u.$</p>	<p>12</p> <p>.....</p> <p>.....</p> <p>$u,$</p> <p>.....</p> <p>.....</p> <p>.....</p> <p>.....</p> <p>$f.$</p> <p>$m_0.$</p>
<p>13</p> <p>.....</p> <p>.....</p> <p>1500</p> <p>.....</p> <p>10 ,</p> <p>3000 / .</p>	<p>14</p> <p>10 ,</p> <p>.....</p> <p>1 .</p> <p>20</p> <p>.....</p> <p>45</p>

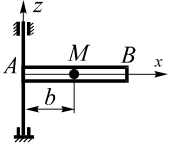
<p>15</p> <p>,</p> <p>,</p> <p>$u = \text{const},$ $m_0?$</p>	<p>16</p> <p>,</p> <p>,</p> <p>,</p> <p>,</p> <p>u</p> <p>,</p> <p>,</p>
<p>17</p>  <p>z</p> <p>b</p> <p>$u.$</p> <p>,</p> <p>,</p> <p>$m_0.$</p>	<p>18</p> <p>,</p> <p>,</p> <p>$v,$</p> <p>,</p> <p>$R,$</p> <p>,</p> <p>$\mu.$</p> <p>,</p> <p>$s,$</p> <p>,</p> <p>,</p> <p>$m_0,$</p> <p>,</p> <p>,</p>

<p>19</p> <p>$f.$, $m = m_0 - \mu t .$</p> <p>$u.$</p> <p>?</p>	<p>20</p> <p>18 / .</p> <p>3600 ;</p> <p>6 ;</p> <p>$v = 25 /c.$</p> <p>?</p>
<p>21</p> <p>$m = m_0 e^{-\alpha t} ,$ m_0 -</p> <p>u ,</p>	<p>22</p> <p>$F.$</p> <p>$m = m_0 e^{-\alpha t} ,$ m_0</p>
<p>23</p> <p>$m = m_0 - \mu t ,$ m_0 μ -</p> <p>$u = \text{const.}$</p>	<p>24</p> <p>15</p> <p>2500 / .</p> <p>15 ?</p>

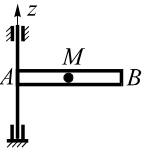
<p>25</p>  <p> z M A B m_0 u </p>	<p>26</p> <p> u m_0 $?$ </p>
<p>27</p> <p> f u $m = m_0 e^{-\alpha t}$ </p>	<p>28</p> <p> $m = m_0 e^{-\alpha t}$ $u = u_0 e^{\beta t}$ m_0, u_0 </p>
<p>29</p> <p> v_0 $m = m_0 - \mu t$ g </p>	<p>30</p> <p> u m_0 </p>

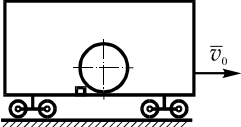
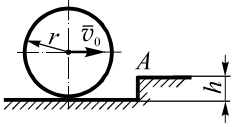
<p>1</p> <p>$m_1,$ $v_1,$</p> <p>$m_2,$</p>	<p>2</p> <p>$h_1 = 1$</p> <p>$h_2 = 0,6$</p>
<p>3</p> <p>30°</p> <p>$3 / ,$</p> <p>$- 45^\circ$</p>	<p>4</p> <p>$0,1$</p> <p>$v_1 = 10 /$</p> <p>$\alpha_1 = 45^\circ$</p> <p>$v_2 = 8 / , \alpha_2 = 60^\circ$</p>
<p>5</p> <p>$0,6$</p> <p>$v = 10 / .$</p> <p>$0,0003$</p>	<p>6</p> <p>$m_1,$ $v_1,$</p> <p>$m_2,$ $v_2.$</p>
<p>7</p> <p>$v_0,$ $r,$</p> 	<p>8</p> <p>r</p> <p>$v_0.$</p>  <p>$h.$</p>

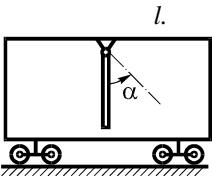
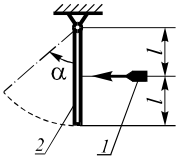
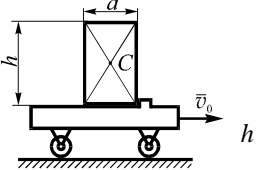
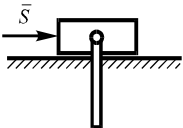
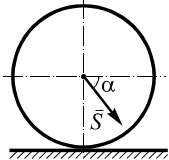
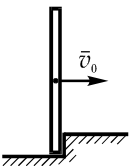
<p>9</p>  <p>l</p> <p>α</p> <p>?</p>	<p>10</p>  <p>m_1</p> <p>v</p> <p>α</p> <p>$2l$</p> <p>l</p> <p>m_2</p> <p>α</p>
<p>11</p>  <p>a</p> <p>h</p> <p>C</p> <p>\vec{v}_0</p> <p>h</p> <p>I_c</p>	<p>12</p>  <p>\vec{S}</p> <p>m</p> <p>h</p> <p>l</p> <p>S</p>
<p>13</p>  <p>m</p> <p>r</p> <p>S</p> <p>α</p> <p>f</p>	<p>14</p>  <p>v_0</p> <p>S</p> <p>h</p>

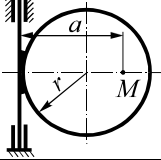
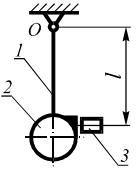
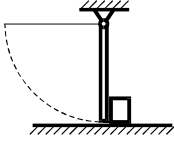
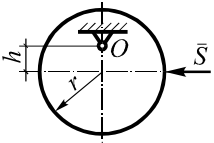
<p>15</p> <p>$m_1,$ $v_1,$ $v_2,$ $m_2.$</p>	<p>16</p> <p>m_1 $m_2.$? .</p>
<p>17</p> <p>$r.$</p> 	<p>18</p> <p>m_1 v_1 $v_2,$ $m_2,$.</p>
<p>19</p> <p>l .</p>	<p>20</p>  <p>1 2 , 80 2 12 , 10 . l 3, .</p>
<p>21</p> <p>$3m$ l  .</p> <p>m</p>	<p>22</p> <p>$r,$  . h .</p>

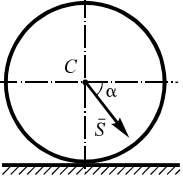
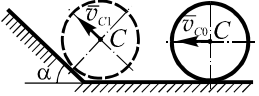
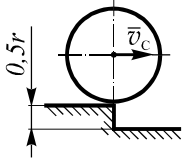
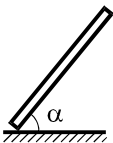
<p>23</p> <p>α</p>	<p>24</p> <p>$m_1, m_2,$</p> <p>$v_1, v_2 (v_1 > v_2)$</p> <p>$k.$</p>
<p>25</p> <p>$m, r,$</p> <p>$S,$</p> <p>α</p> 	<p>26</p>  <p>$v_0,$</p> <p>v_1</p> <p>α</p>
<p>27</p> <p>$45^\circ,$</p>	<p>28</p> <p>β</p> <p>α</p>
<p>29</p> <p>$r,$</p> <p>$v,$</p> <p>$0,5 r,$</p> 	<p>30</p> <p>$l,$</p> <p>α</p> <p>$v_0.$</p> 

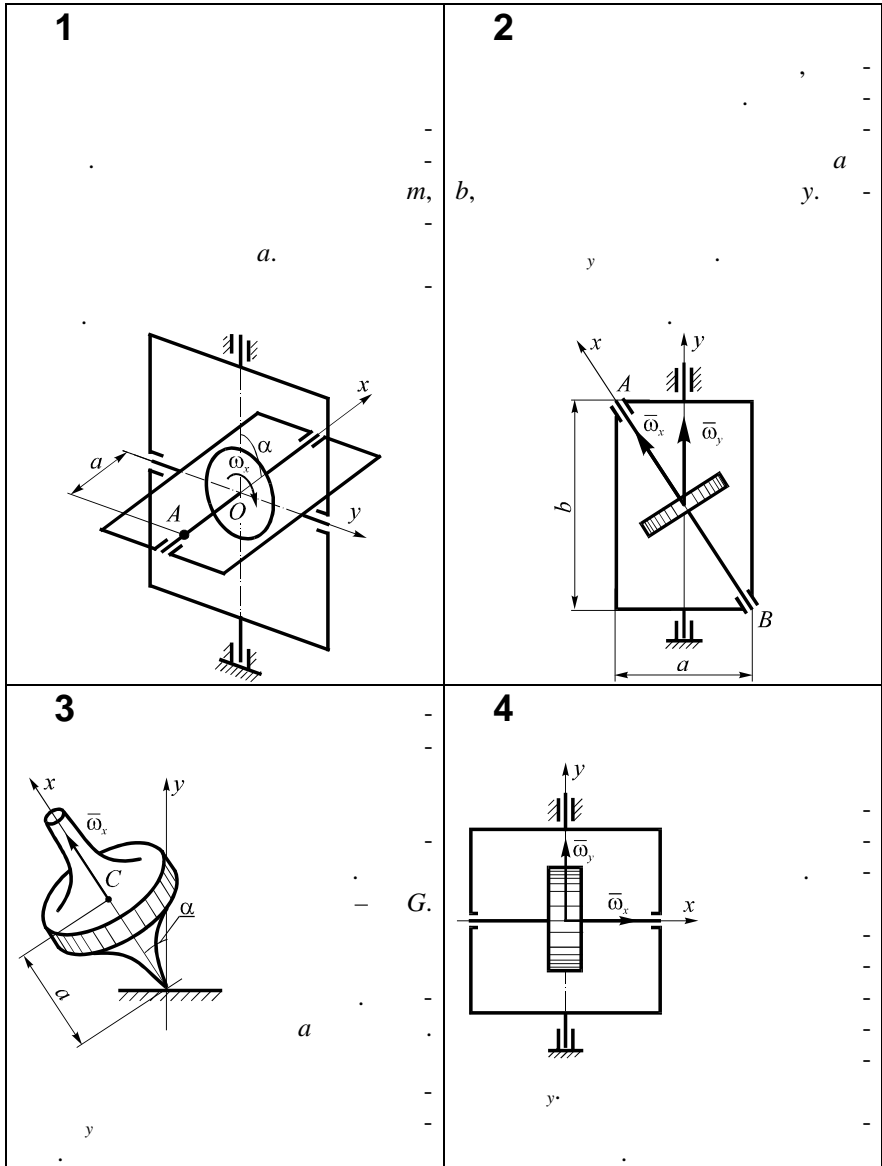

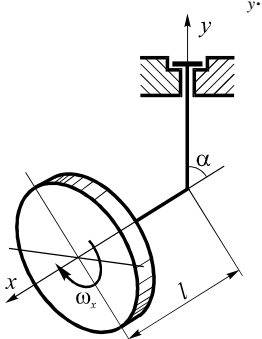
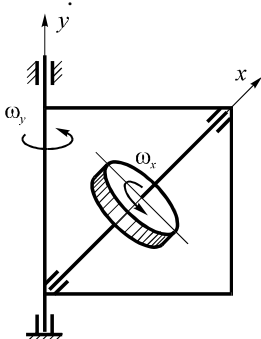
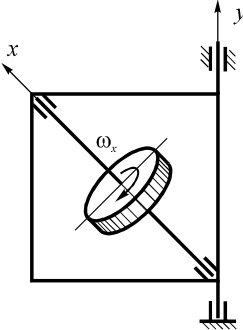
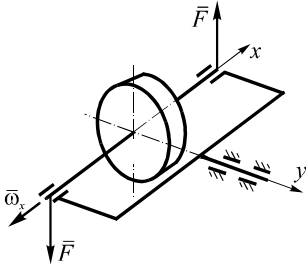
<p>5</p> <p>m $r,$</p> <p>l</p> 	<p>6</p> <p>a</p> <p>y</p> <p>y'</p> <p>m $r.$</p> 
<p>7</p> <p>a</p> <p>y</p> <p>y'</p> 	<p>8</p> <p>$F,$</p> <p>?</p> 

9

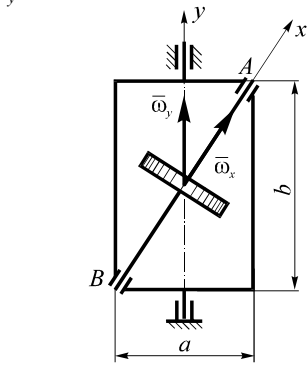

10

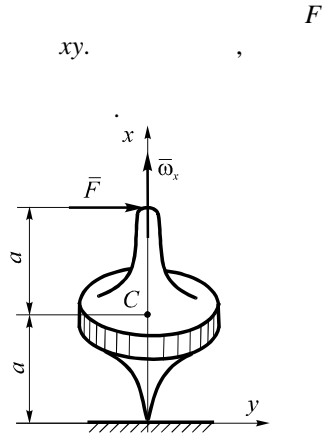

11

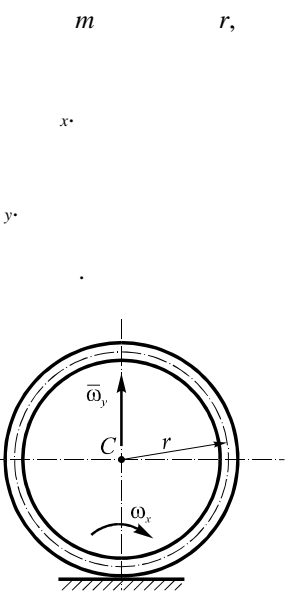

12

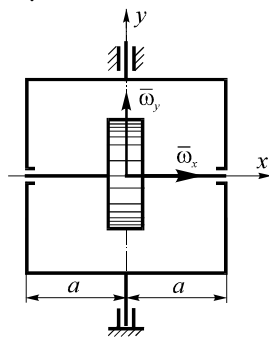

13

F .

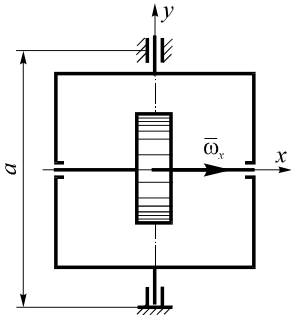

14

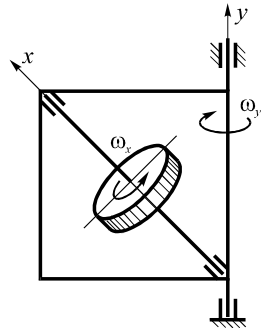

15

1

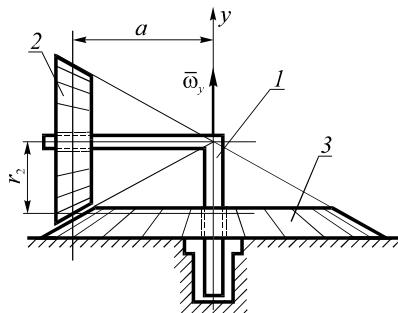

16

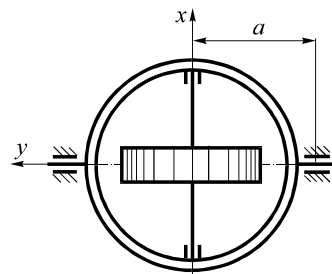

17

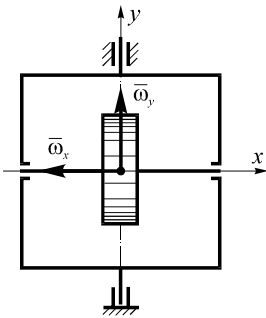

18

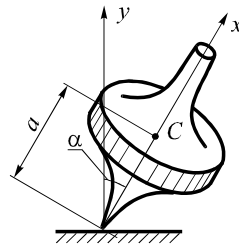

19

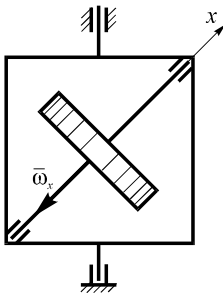

20

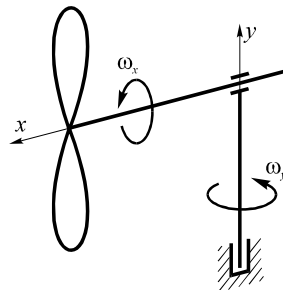

21

y

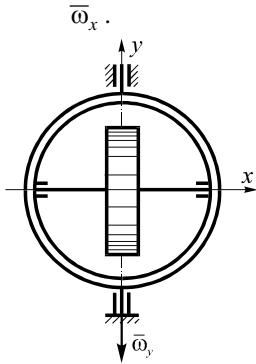

y

22

-
 G ;

y .

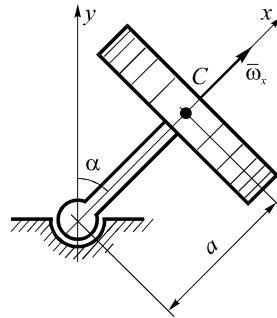

23

1

y

y

G ;

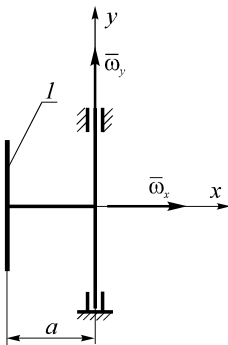

24

G ,

a

y

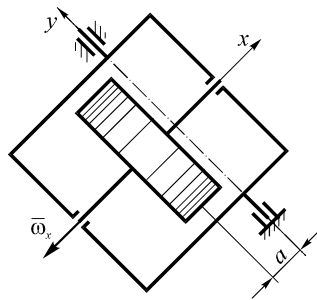

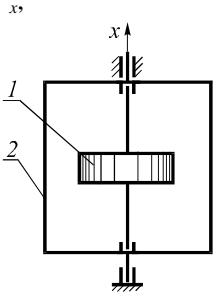
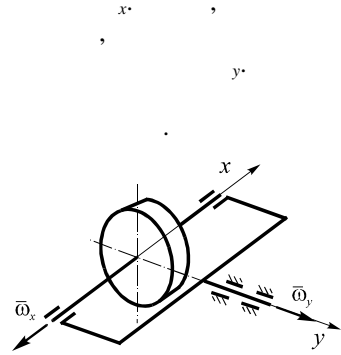
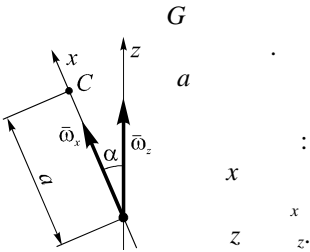
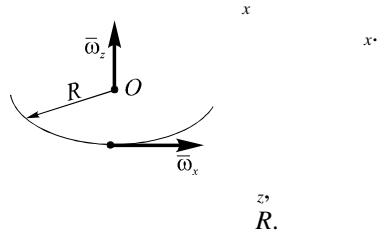
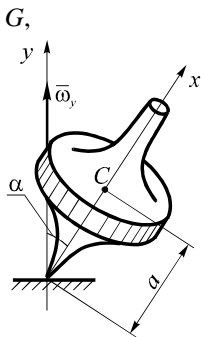
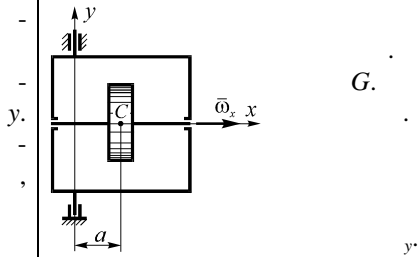
25**26****27****28****29****30**

- 12. .- .: ,1991.- 638 .
 - 2-
 - 3 - .:
 - 4 - .: ,1995.-
- 416 .



« »

15.08.2002 . 60×84 ¹/₁₆.
“ ”
. . . 3,95. . . . 3,74. 250 .
. 1541. . 3852.
- ,246653, . . . ,34.
57 22.10.97 .
,246022, . , . ,34.
360 26.07.99 .